

BRAKE SYSTEM

GENERAL	BRa - 2
SPECIFICATIONS	BRa - 5
SERVICE STANDARDS	BRa - 6
SERVICE PROCEDURE	BRa - 9
TROUBLESHOOTING	BRa-56

GENERAL SERVICE BRAKE

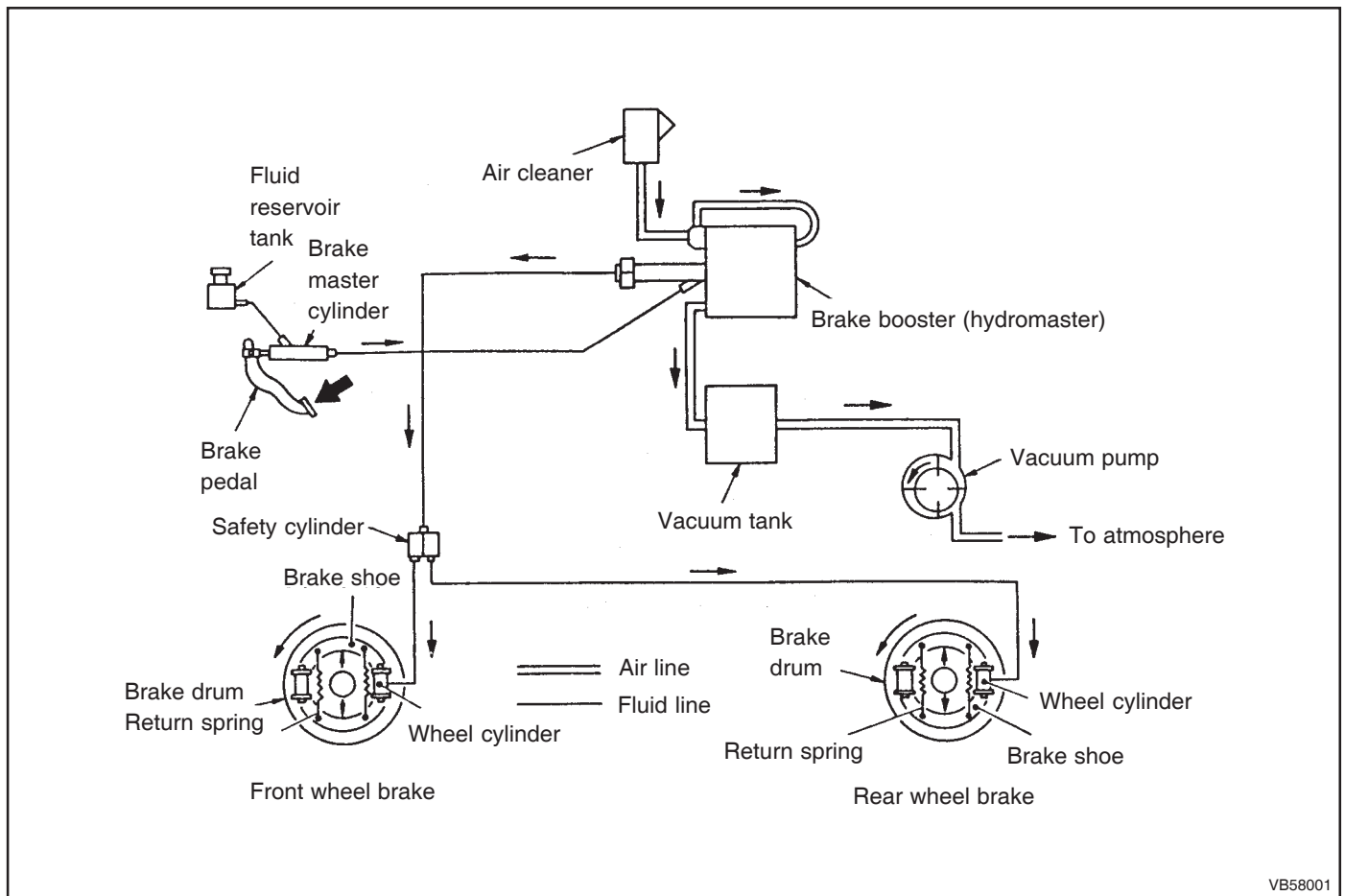

The service brakes are vacuum servo hydraulic brake consisting of devices such as brake master cylinder, brake booster (hydromaster) and wheel cylinders and are used to decelerate or stop the traveling vehicle.

When the pedal is depressed, the depression force is converted into a hydraulic pressure, which is then amplified by the brake booster (hydromaster) and acts on the wheel cylinders. The wheel cylinders press the brake shoes against the brake drums to produce a frictional force

Vacuum Pump

- 1) The vacuum pump which is installed on the back of the alternator has its rotor coupled with the alternator shaft so that it rotates with the alternator. Within its cylindrical housing, as the rotor rotates, its three movable vanes are made to move toward the housing inside surface by centrifugal force, thereby producing pumping action. The resultant vacuum pressure keeps the inside of the vacuum tank at vacuum.

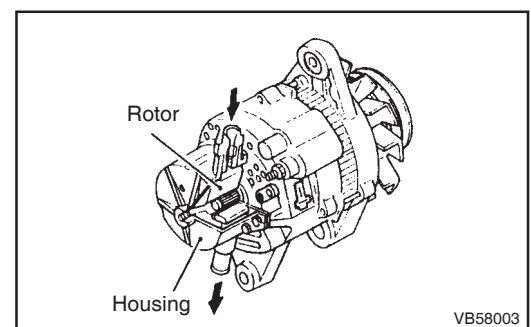

2) The rotor and housing cylinder are eccentrically arranged and air from the vacuum tank is taken through the inlet port into the pump and gradually compressed before it is discharged from the outlet port. Engine oil enters the pump through the oil port and keeps the housing oil tight and lubricates and cools the housing inside. The oil is then discharged from the outlet port with compressed air and returns to the oil pan.

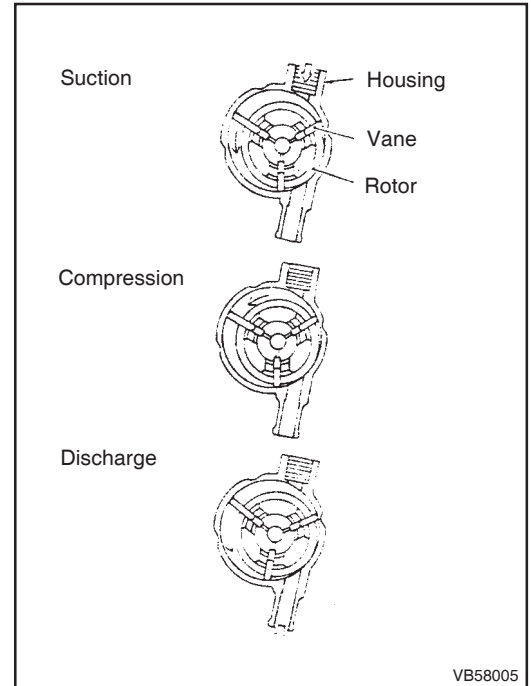

3) A check valve is provided at the inlet port to prevent air and engine oil from flowing back from the vacuum pump to the vacuum tank when the engine is stopped.

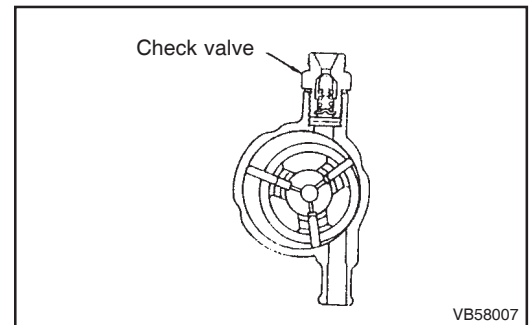

BRAKE BOOSTER (Hydromaster)

1) When brake booster is not operated

Since no fluid pressure acts on the relay valve piston, the vacuum valve is in opened position and the atmosphere valve in closed position.

Since the diaphragm air hole is clear, both chambers A and B of the power cylinder are evacuated and the power piston pressed toward the chamber B by the return spring.

With the hydraulic piston also pulled an the ball check valve opened, the brake fluid passes through the center hole of the hydraulic piston and flows into the hydraulic cylinder.

When the brake booster is not in operation, therefore, the hydraulic piston serves only as a fluid path.

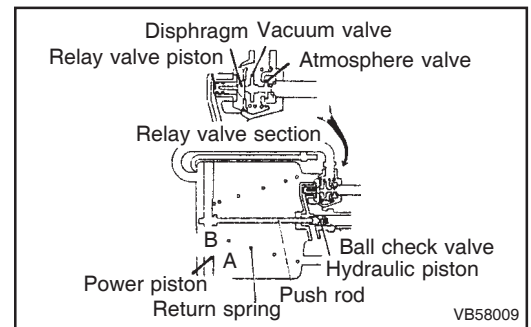

2) When brake booster is operated

When the pedal is depressed, the fluid pressure from the master cylinder acts on the relay valve piston and hydraulic piston.

The diaphragm, pushed by the fluid pressure acting on the back surface of the relay valve piston, closes the vacuum valve. As soon as the vacuum valve is closed, the atmosphere valve is opened, so the atmospheric air from the air cleaner enters the power cylinder.

At the time, a pressure difference is produced between the chambers A and B. The force produced by the pressure difference overcomes the return spring and the power piston moves the push rod to push the hydraulic piston.

When the hydraulic piston operates, the ball check valve is closed and the brake fluid passage between the master cylinder and the hydraulic cylinder is closed, preventing backflow of the high pressure fluid generated in the hydraulic cylinder to the master cylinder and instead transmitting the hydraulic pressure to the wheel cylinder. The hydraulic pressure developing in the hydraulic cylinder is the sum of the thrust transmitted from the power piston to the hydraulic piston and the pressure acting directly on the hydraulic piston from the brake master cylinder.

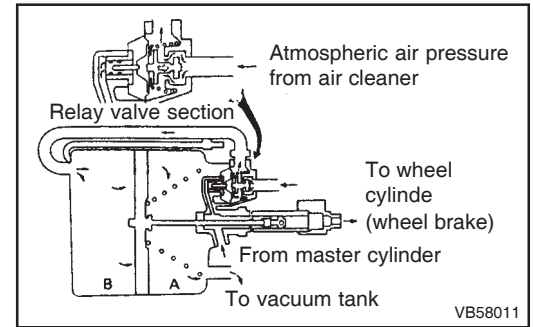

SPECIFICATIONS

Unit:mm

Item	Vehicle model HD120
Brake type	Hydro-vacuum servo hydraulic brake acting on all wheels, internal expansion type
Front	2-leading type
Rear	Dual 2-leading type
Vacuum pump	
Type	Vane type
Delivery rate	120 cc
Brake booster (hydromaster)	
Power cylinder	
I.D. x stroke	241.3 x 163
Hydraulic cylinder	
I.D. x stroke	19.05 x 159
Relay valve piston	
O.D.	25.4
Safety cylinder	
I.D. x stroke	30 x 32
Vacuum tank	
Capacity	30lit.
Wheel brake	
Brake drum I.D. (limit)	320 (322)
Brake lining width x thickness (limit)	
Front	120 x 11.6 (5.0)
Rear	150 x 11.6 (5.0)
Brake shoe clearance	0.2 ~ 0.3
Wheel cylinder I.D.	
Front	36.51°
Rear	38.1

SERVICE STANDARDS

SERVICE STANDARDS TABLE

Service brakes

Maintenance item		Nominal (Basic diameter in [])	Limit	Remedy and remarks	
Brake pedal	Free travel of brake pedal		3.5 to 9.2	Adjust by push rod of brake master cylinder	
	Pedal shaft to bushing clearance		[20] 0.06 to 0.24	0.4	Replace bushing
	Return spring	Load/installed length	45 N (4.6 kgf)/124.2	38 N (3.9 kgf)/124.2	Replace
Brake master cylinder	Cylinder to piston clearance		[38.1] 0.05 to 0.14	0.2	Replace piston
	Return spring	Free length	125	100	Replace
Brake booster (hydro-master)	Valve seat spring	Load N (kgf)/ installed length	54 to 64 (5.5 to 6.5)/30.2	49 (5.0)/30.2	Replace
	Piston return spring		160 to 195 (16.2 to 19.8)/181	140 (14.5)/181	
	Valve fitting to relay valve piston clearance		[25.4] 0.04 to 0.11	0.13	Replace piston
	Hydraulic piston to cylinder clearance		[19.5] 0.05 to 0.13	0.15	Replace piston
	Valve body guide wear depth		-	0.5	Replace
	Bend of push rod		0.13 or less	0.3	Replace
	Fluid tightness	Apply 11.8 MPa (120 kgf/cm ²) fluid pressure to hydraulic cylinder and measure amount fluid pressure falls in 15 seconds	1.47MPa (15kgf/cm ²) or less		Check and replace related parts
	Air tightness when not operating	Set vacuum pressure in brake booster to 67 kPa (500 mmHg), close cock, and measure amount vacuum pressure falls in 15 seconds	3.3kPa (25mmHg) or less		
	Operation starting pressure	Set vacuum pressure in brake booster to 67 kPa (500mmHg). Slowly apply pressure from master cylinder and read pressure indicated by master cylinder pressure gauge when pointer of vacuum gauge deflects	125 to 225 kPa (1.3 to 2.3 kgf/cm ²)	105 to 245 kPa (1.1 to 2.5 kgf/cm ²)	

Maintenance item			Nominal (Basic diameter in [])	Limit	Remedy and remarks		
Brake booster (hydro-master)	Operation at full load	Set vacuum pressure in brake booster to 67 kPa (500mmHg). Slowly depress pedal of master cylinder and read pressure indicated by hydraulic cylinder pressure gauge for master cylinder pressure gauge	1.57 kPa (16 kgf/cm ²)/ 10.1 to 11.1 kPa (103 to 113kgf/cm ²)	1.57 kPa (16 kgf/cm ²)/ 9.81 to 11.4 kPa (100 to 116 kgf/cm ²)			
	Air tightness at full load	Block vacuum supply at full load and read amount vacuum pressure falls in 15 seconds thereafter	3.3 kpa (25mmHg) or less				
	Residual pressure	Set master cylinder pressure to 490 kPa (5 kgf/cm ²), loosen air bleeder screw at end of hydraulic cylinder to release master cylinder pressure, and read pressure indicated by wheel cylinder pressure gauge	78 to 125 kPa (0.8 to 1.3 kgf/cm ²)	59 to 155 kPa (0.6 to 1.6 kgf/cm ²)	Check and replace related parts		
Safety cylinder	Return spring	Load/installed length	18 to 2 N (1.81 to 2.21 kgf)/48	15 N (1.5 kgf)/48	Replace		
	Cylinder to piston clearance		[30] 0.06 to 0.12	0.17	Replace piston		
Brake drum	Inside diameter	Vehicle with 320 drum	320	322 *321	Replace Mark * shows standard inside diameter when oversize lining is used		
	Cylindricity		0.05	0.2	Correct		
Brake shoe return spring	Front	Load/installed length	325 N (33 kgf)/192	If gaps between coils or between coil and cover are evident	Free length 180.5	Re- place	
			380 N (39 kgf)/228.4		Free length 215.2		
	Rear	Load/installed length	390 N (40 kgf)/217		If gaps between coils or between coil and cover are evident	Replace	
			380 N (39 kgf)/228.4				
420 N (43 kgf)/266.5							
Brake shoe	Brake lining thickness		12.0	5	Replace linings Side shoulder means wear limit		

Maintenance item			Nominal (Basic diameter in [])	Limit	Remedy and remarks	
Wheel cylinder	Piston to body clearance	Front	[34.93] 0.03 to 0.09	0.2	Replace	
		Rear	[36.51] 0.03 to 0.09			
	Piston to body clearance	Load/installed length	15 N (1.5 kgf)/14.2	12 N (1.2 kgf)/14.2	Free length 47.5	Re- place
Brake shoe clearance			0.2	1.0	Adjust	

TIGHTENING TORQUE TABLE

Service brakes

Location tightened			Screw size O.D. x pitch(mm)	Tightening torque Nm (kgfm)
Brake pedal	Brake pedal shaft bolt and nut		M12 x 1.25	48 (4.9)
	Brake pedal to master cylinder attaching bolt and nut		M12 x 1.25	72 (7.3) 60 (6.1)
	Brake master cylinder bolt		M12 x 1.25	48 (4.9)
	Brake master cylinder push rod adjusting nut		M12 x 1.25	25 to 34 (2.5 to 3.5)
Brake master cylinder nipple			M12 x 1.5	44 to 64 (4.5 to 6.5)
Brake booster (hydromaster)	Valve fitting		M36 x 1.5	3.9 to 9.8 (0.4 to 1)
	Hook bolt and nut		M10 x 1.25	1 to 2 (0.1 to 0.2)
	Valve body screw		M4 x 10.7	145 to 245 (15 to 25)
	Cylinder cap		M33 x 1.5	59 to 98 (6 to 10)
	Cylinder lock nut		M33 x 1.5	39 to 54 (4 to 5.5)
	Power piston nut		M14 x 1.5	15 to 39 (1.5 to 4)
	Elbow assembly		PT 1/2	15 to 39 (1.5 to 4)
	Hose connector		PT 1/2	0.3 to 0.8 (0.03 to 0.08)
	Poppet valve assembly nut		M3.5 x 0.6	6.9 to 8.8 (0.7 to 0.9)
	Air bleeder screw		M10 x 1.25	235 to 265 (24 to 27)
Safety cylinder	Cylinder cap		-	78 to 98 (8 to 10)
	Check bolt and nut		M20 x 1.5	35 to 53 (3.6 to 5.4)
Wheel brake	Wheel cylinder bolt	Front	M10 x 1.5	63 to 94 (6.4 to 9.6)
			M12 x 1.75	63 to 94 (6.4 to 9.6)
		Rear	M12 x 1.75	63 to 94 (6.4 to 9.6)
	Pipe assembly tightening		M10 x 1.0	12 to 16 (1.2 to 1.6)
	Pipe connector bolt	Front	M8 x 1.25	7.8 to 12 (0.8 to 1.2)
	Pipe clamp bolt	Vehicle with 320 drum	M6 x 1.0	3.9 to 5.9 (0.4 to 0.6)
	Bleeder screw		M10 x 1.0	7.8 to 12 (0.8 to 1.2)

Location tightened		Screw size O.D. x pitch (mm)	Tightening torque Nm (kgfm)
Wheel brake	Wheel cylinder	Stop perspring screw	5.9 to 9.8 (0.6 to 1)
	Brake pipe tightening	4.76	12 to 16 (1.2 to 1.6)
		6.35	19 to 25 (1.9 to 2.6)

SERVICE PROCEDURE
BRAKE SYSTEM DIAGRAM

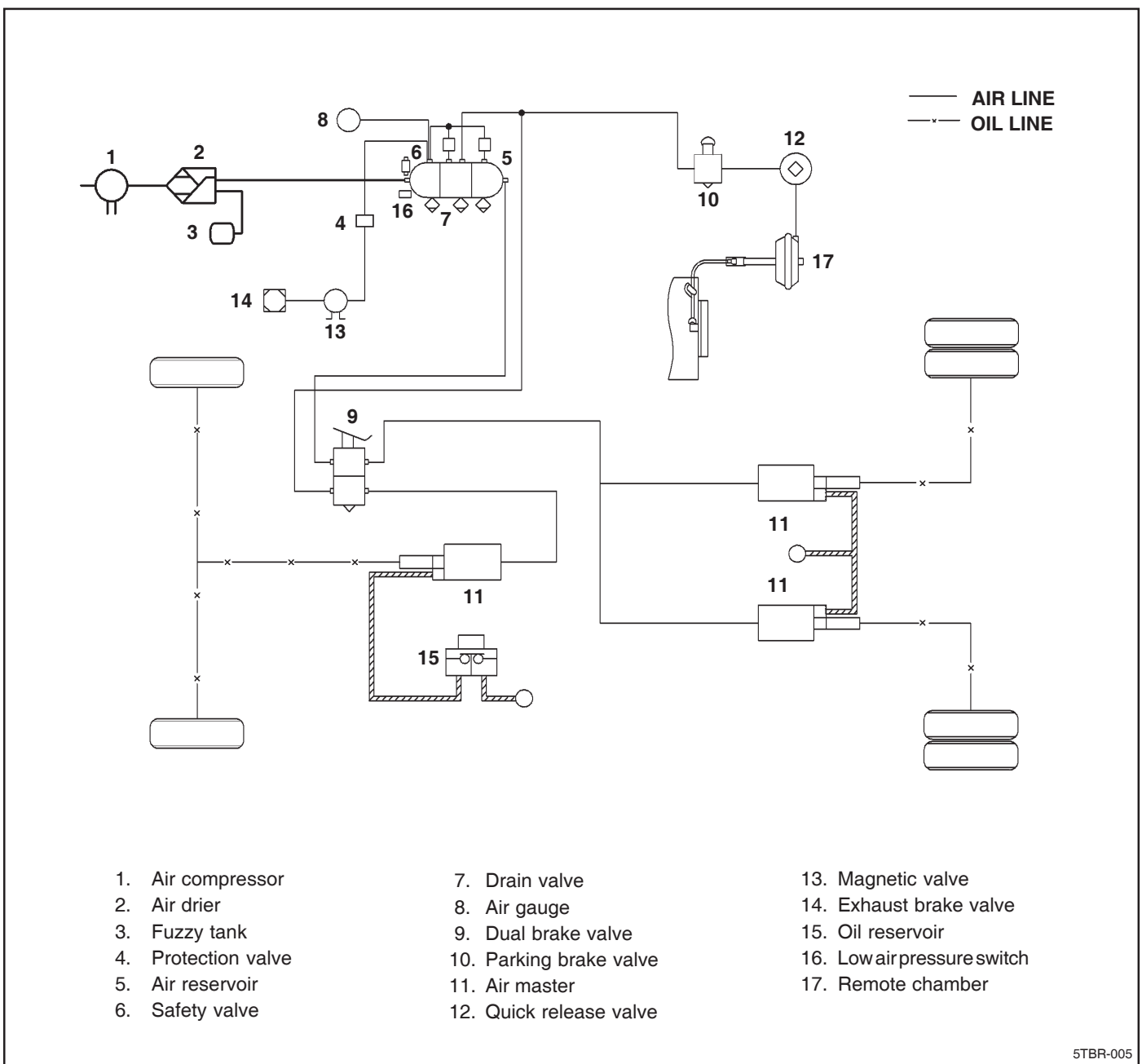

VACUUM PUMP

Disassembly, inspection and reassembly

1. Vacuum housing
2. Rotor
3. Vane
4. Plate

Reverse the disassembly procedure to assemble.

NOTE
When reassembling, check the parts for metal dust and other foreign matter.

VB58015

Testing

- a) Set up as illustrated and turning the alternator pulley, measure performance of the vacuum pump. If the measured value is less than the nominal value, disassemble and check for vane damage, housing, rotor and plate contact surface damage. Replace if any defect is found.

Ultimate vacuum

Nominal value	Vacuum	91 kPa (680 mmHg) or more
	Speed	3000 rpm

Evacuation characteristic after 20 seconds (with 10 lit. tank load)

Nominal value	At low speed	Vacuum	73 kPa (550 mmHg) or more
		Speed	1500 rpm
	At low speed	Vacuum	80 kPa (600 mmHg) or more
		Speed	3000 rpm

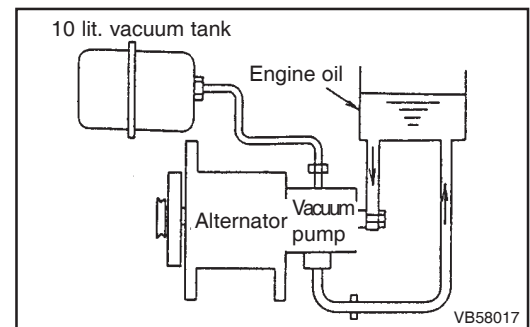

BRAKE FLUID TANK

Inspection of reed switch function

- 1) Draining of brake fluid
 - a) Remove the radiator grille from the front of the cab and remove the brake fluid pipes for brake and clutch.

NOTE

Brake fluid will mar the paint. Wipe out quickly if spilled.

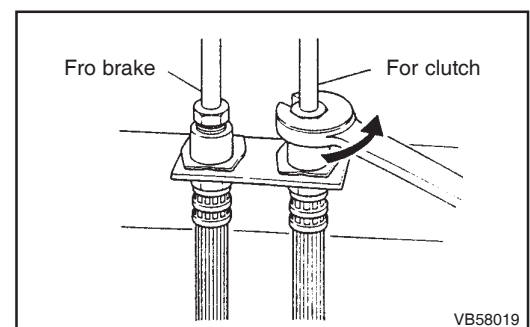

- b) With one end of the removed pipes placed in a container, depress the brake pedal repeatedly until the fluid level in the brake fluid tank falls to "L" level line.

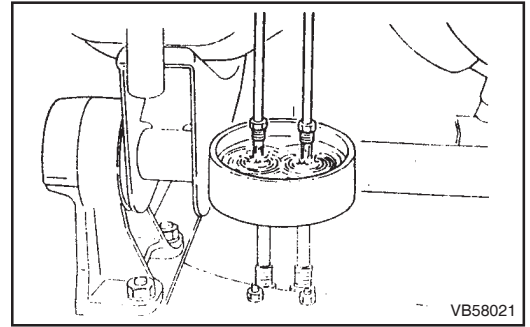

2) Inspection

Check that the warning lamp in the meter cluster lights up when the brake fluid level falls to the "L" level. If not, replace the brake fluid tank assembly.

NOTE

Check with the engine running.

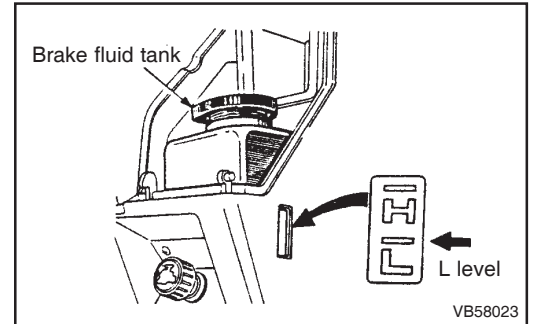

BRAKE PEDAL

Removal

- 1) Depress the brake pedal and clutch pedal repeatedly to drain brake fluid from the brake fluid tank.
- 2) Remove the meter hood, meter cluster, instrument corner, panel and instrument control panel side cover.

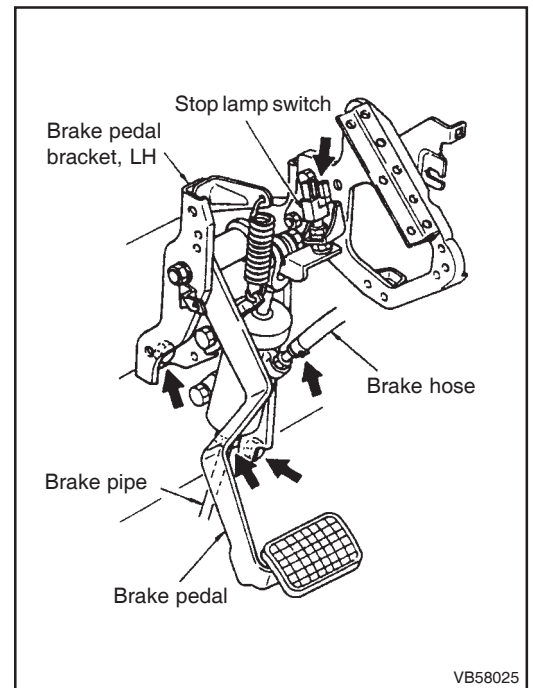

Disassembly, inspection and correction

BD ... Basic Diameter
 NV ... Nominal Value
 L ... Limit

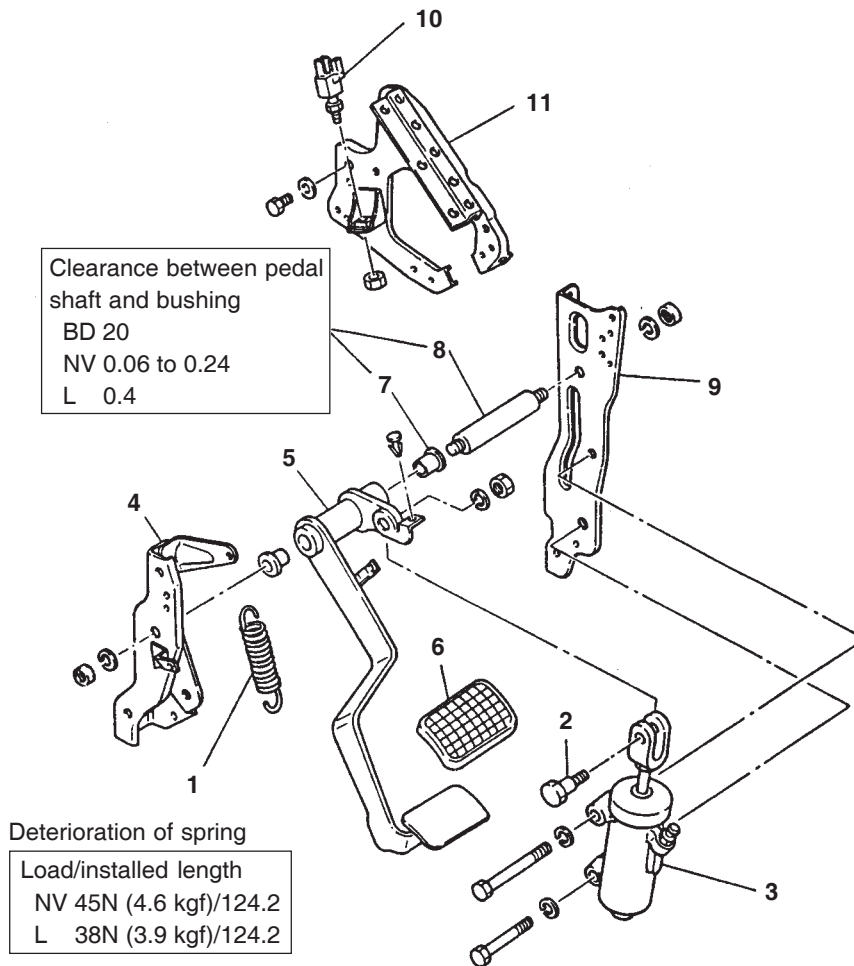

Disassembly sequence

1. Return spring
2. Bolt
3. Brake master cylinder
4. Brake pedal
5. Brake pedal
6. Pedal pad
7. Bushing
8. Pedal shaft
9. Brake pedal bracket, RH
10. Stop lamp switch
11. Meter cluster bracket

Reassembly and adjustment

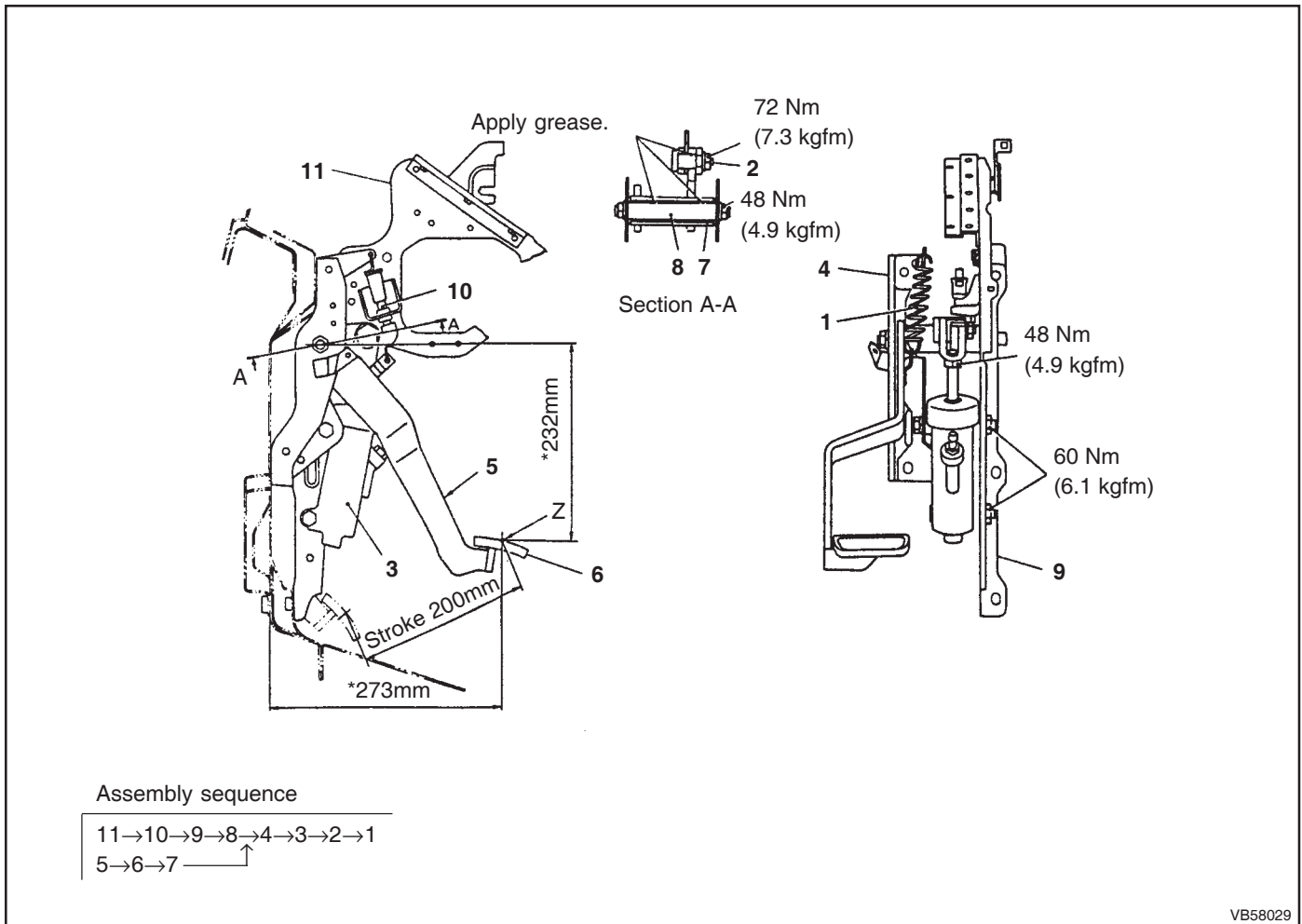

VB58029

- 1) Rotate the stop lamp switch to adjust the brake pedal pad center position (point Z) to the dimension marked *, and then secure it with the lock nut.
At this point, check to ensure that the stop lamp switch is in the OFF state.
- 2) Check to ensure that when the brake pedal is depressed all the way, the full stroke is 200mm.
- 3) Rotate the brake master cylinder push rod to adjust the free travel of the brake pedal pad center position (point Z) to 3 to 9mm, and tighten the lock nut to the specified torque.
- 4) After adjustments, remove the air from inside the brake system and clutch system (refer to Group 41 clutch). After bleeding, depress the brake pedal several times to check for air leaks from the brake pipe and brake hose connections.
- 5) Clearance between brake pedal and floor board
Start the engine and depress the brake pedal by 590N (60kgf) to check that the clearance between the brake pedal and floor board is 65mm or more.

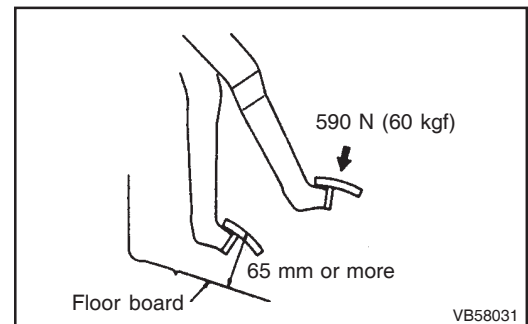

VB58031

BRAKE MASTER CYLINDER

Disassembly and Inspection

BD ... Basic Diameter
 NV ... Nominal Value
 L ... Limit

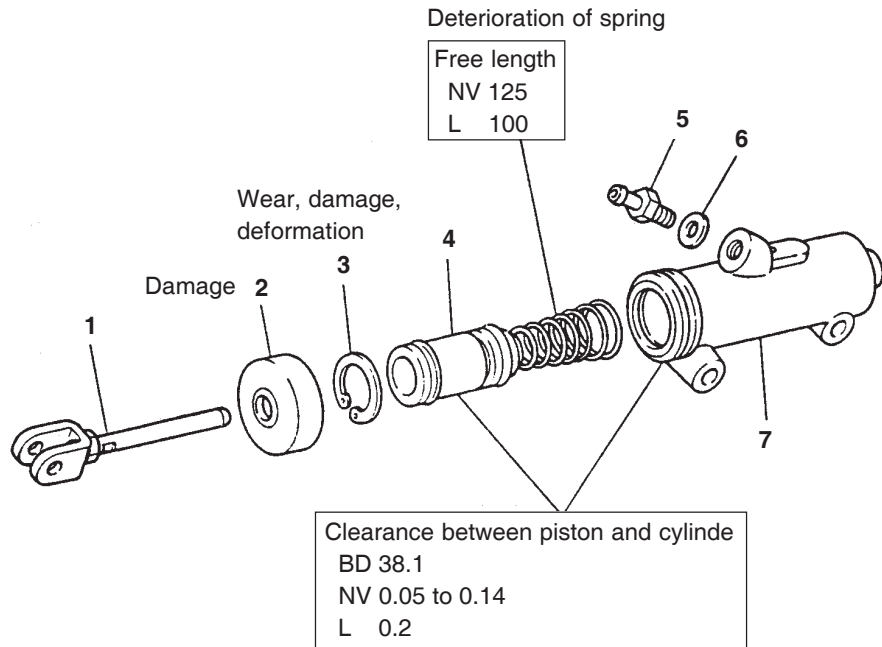

- Disassembly sequence
1. Push rod complete
 2. Boot
 3. C-ring
 4. Piston complete
 5. Nipple
 6. Gasket
 7. Cylinder

VB58033

Reassembly

Repair kit:
 Brake master cylinder kit.

25 to 34 Nm
 (2.5 to 3.5 kgfm)

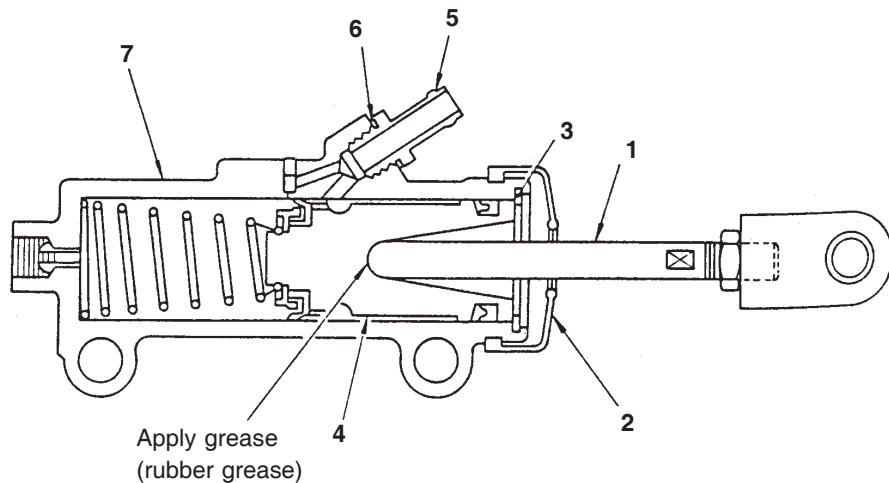

Assembly sequence

7→6→5→4→3→2→1

NOTE

Apply an ample amount of assembling oil (NA-166M or equivalent) to cylinder bore and the entire periphery of secondary cup of piston complete.

VB58035

Removal and installation**NOTE**

When the oil pipe is removed, use care to make sure that brake fluid is not split on the frame or bracket.

Disassembly, inspection and correction**NOTE**

1. **Before disassembly, remove dirt and dust from the surface and use care not to allow foreign matter, dust, dirt or water to enter.**
 2. **Put alignment marks before disassembly.**
 3. **Never immerse rubber parts in cleaning solvent.**
- 1) For inspection and correction, disassemble the brake booster into the relay valve piston section, the hydraulic cylinder section, the power cylinder section and the end plate section.
 - 2) Wipe or wash to clean to disassembled parts as described below.
 - a) Rubber parts or parts containing rubber parts
Wipe with cloth wetted by brake fluid or alcohol.
 - b) Metallic parts
Clean with cleaning fluid (trichlene or metal cleanser), dry with compressed air and completely remove cleaning fluid.

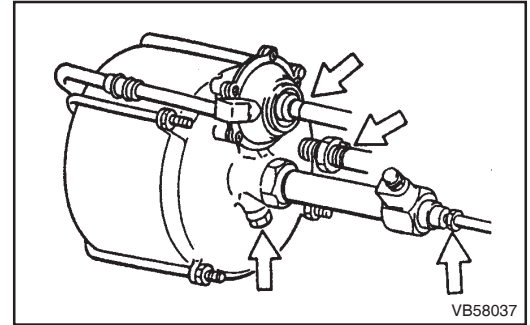

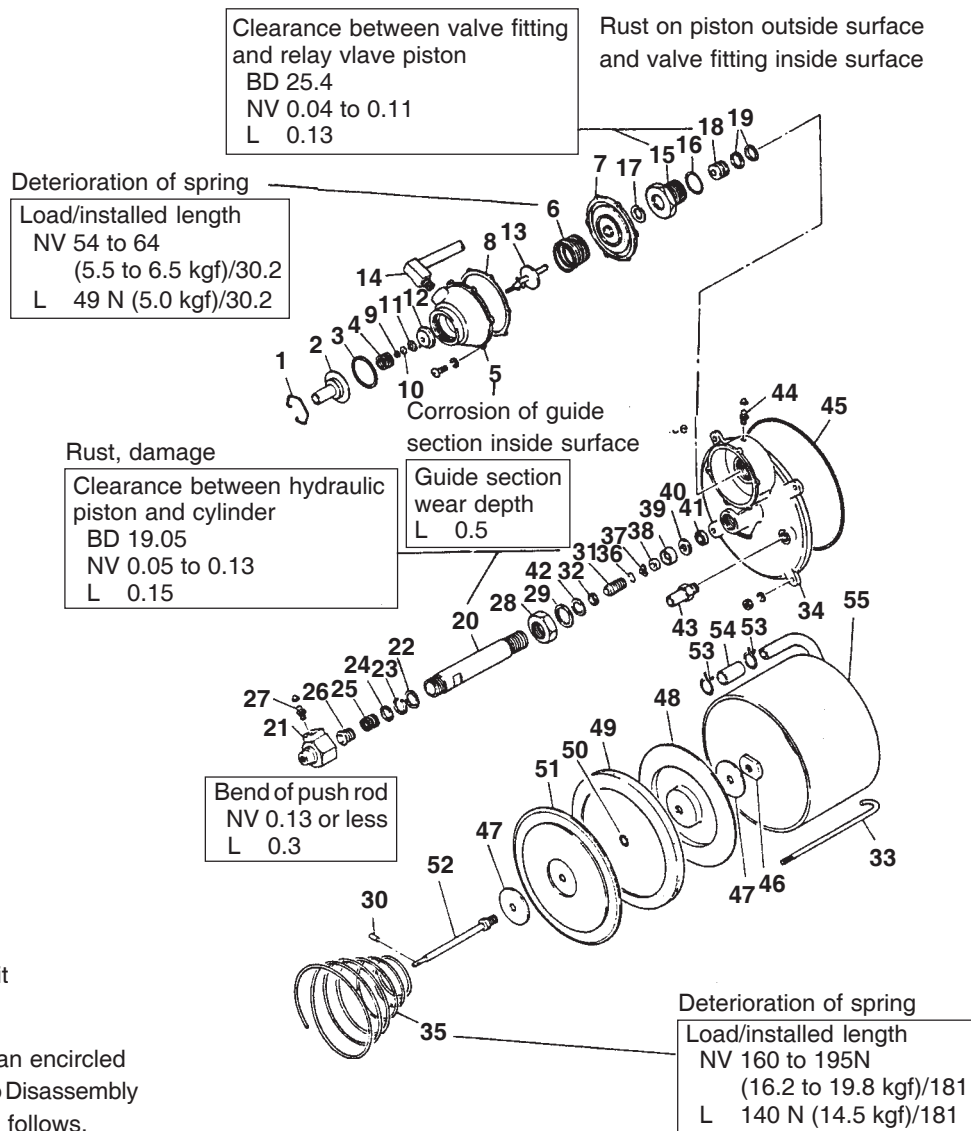

Repair kit:
hydromaster kit

For parts with an encircled number, refer to Disassembly Procedure that follows.

Disassembly sequence

- | | | | |
|----------------------------|---------------------------|-------------------------------|-----------------------------|
| 1. Retaining ring | 15. Valve fitting | 29. Gasket | 43. Hose connector |
| 2. Pipe and cover assembly | 16. O-ring | 30. Straight pin | 44. Plug |
| 3. Gasket | 17. Retaining ring | 31. Hydraulic piston assembly | 45. O-ring |
| 4. Spring | 18. Relay valve piston | 32. Cup packing | 46. Push rod nut |
| 5. Valve body | 19. Cup packing | 33. Hook bolt | 47. Washer |
| 6. Valve seat spring | 20. Cylinder | 34. End plate assembly | 48. Piston plate |
| 7. Diaphragm assembly | 21. Cap | 35. Return spring | 49. Rubber packing |
| 8. Gasket | 22. Gasket | 36. Retaining ring | 50. Gasket |
| 9. Nut | 23. Retaining ring | 37. Washer | 51. Piston plate |
| 10. Gasket | 24. Washer | 38. Retainer | 52. Push rod assembly |
| 11. Poppet | 25. Spring | 39. Cup packing | 53. Clamp |
| 12. Air valve | 26. Outlet valve assembly | 40. Washer | 54. Hose |
| 13. Vacuum valve assembly | 27. Plug | 41. Oil seal | 55. Cylinder shell assembly |
| 14. Elbow assembly | 28. Lock nut | 42. Gasket | |

NOTE

1. Before disassembly, remove dirt thoroughly from the outside of the hydromaster.
2. Before disassembly, put matching marks on mating sections.
3. Wipe or wash clean the disassembled parts as described below.
 - a) Rubber parts and components with rubber parts.
Wipe the parts using clutch wetted with brake fluid or alcohol.
 - b) Metal parts
Wash in cleaning agent (trichlene or metachlene) and remove cleaning agent completely using the compressed air and dry.
4. Check rubber parts visually for damage, wear, swelling, etc. and replace them if any defect is found.

Disassembly Procedure

- 1) Fixing of brake booster

Hold the special tool, Work Bench, in a vice and install four hook bolts of the brake booster, aligning with the guide position of the work bench.

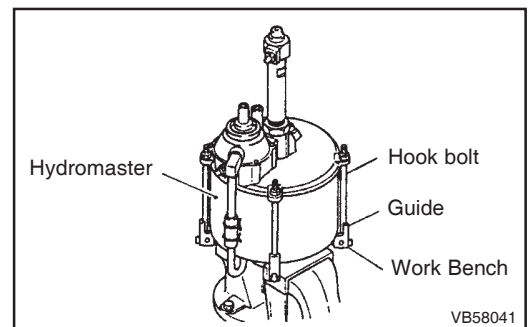

- 2) Remove and installation of relay valve section retaining ring

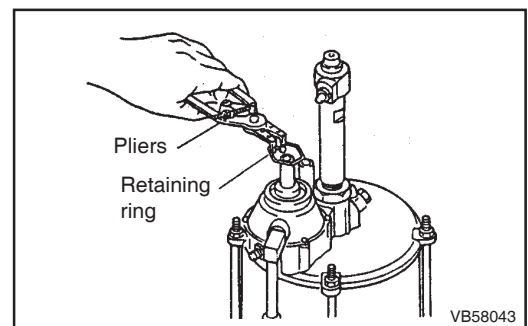

- 3) Removal and installation of relay valve section valve fitting

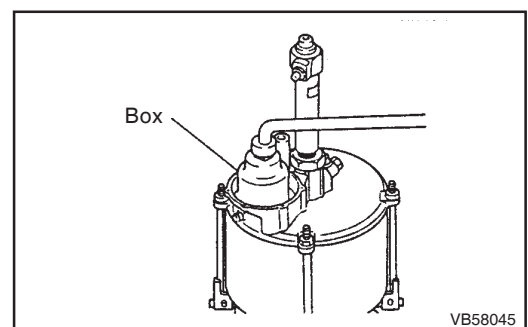

4) Removal of hydraulic cylinder

Loosen the lock nut and then loosen the cylinder by holding it with the special tool, Spanner, on flats.

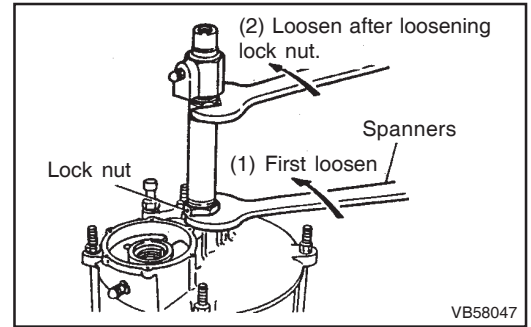

5) Removal of retaining ring from outlet valve

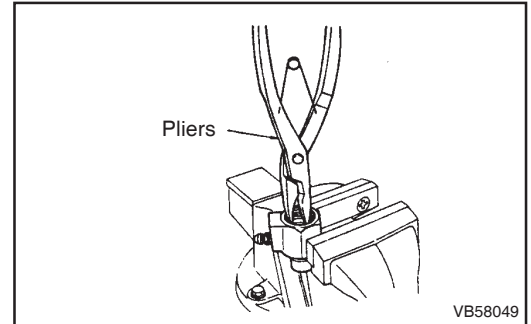

6) Removal of hydraulic piston

a) When compressed air is not used

With the return spring compressed using the special tool, Hook Clamp. Remove the straight pin from the hydraulic piston using a needle or the like.

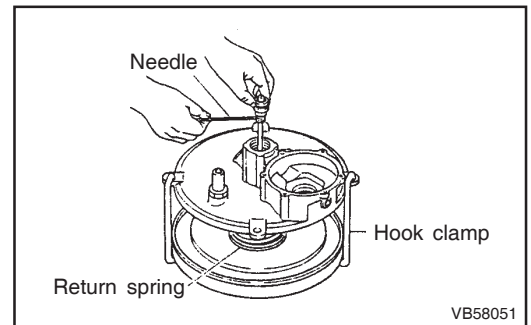

b) When compressed air is used

With compressed air supplied through the cylinder shell pipe to push to the hydraulic piston, remove the straight pin from the hydraulic piston using a needle or the like.

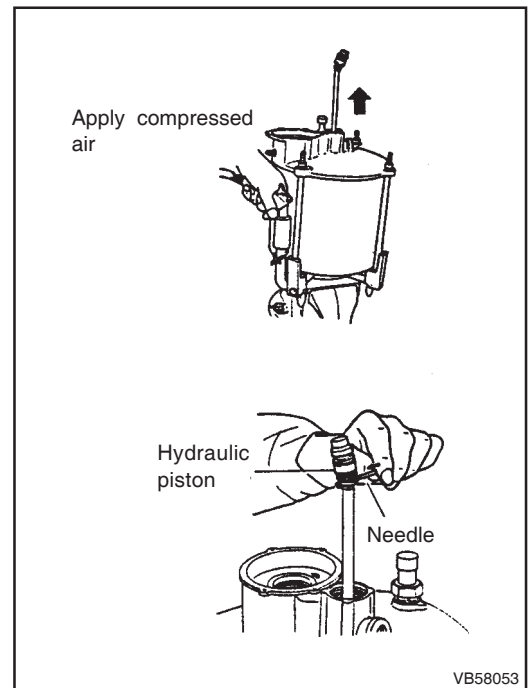

7) Remove of push rod nut from power piston

With the special tool, Ring Assembly, held in a vice, install the power piston, aligning its push rod nut with the flat portion of the ring assembly. Then align the push rod nut with the flat portion of the special tool. Socket, and remove the push rod nut.

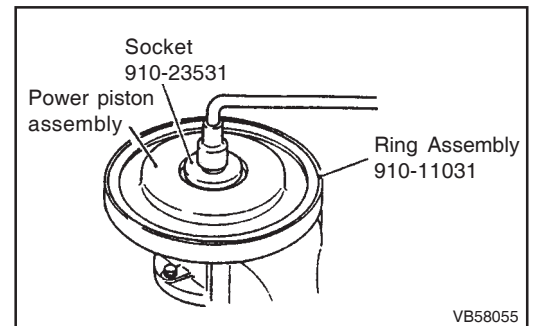

Reassembly

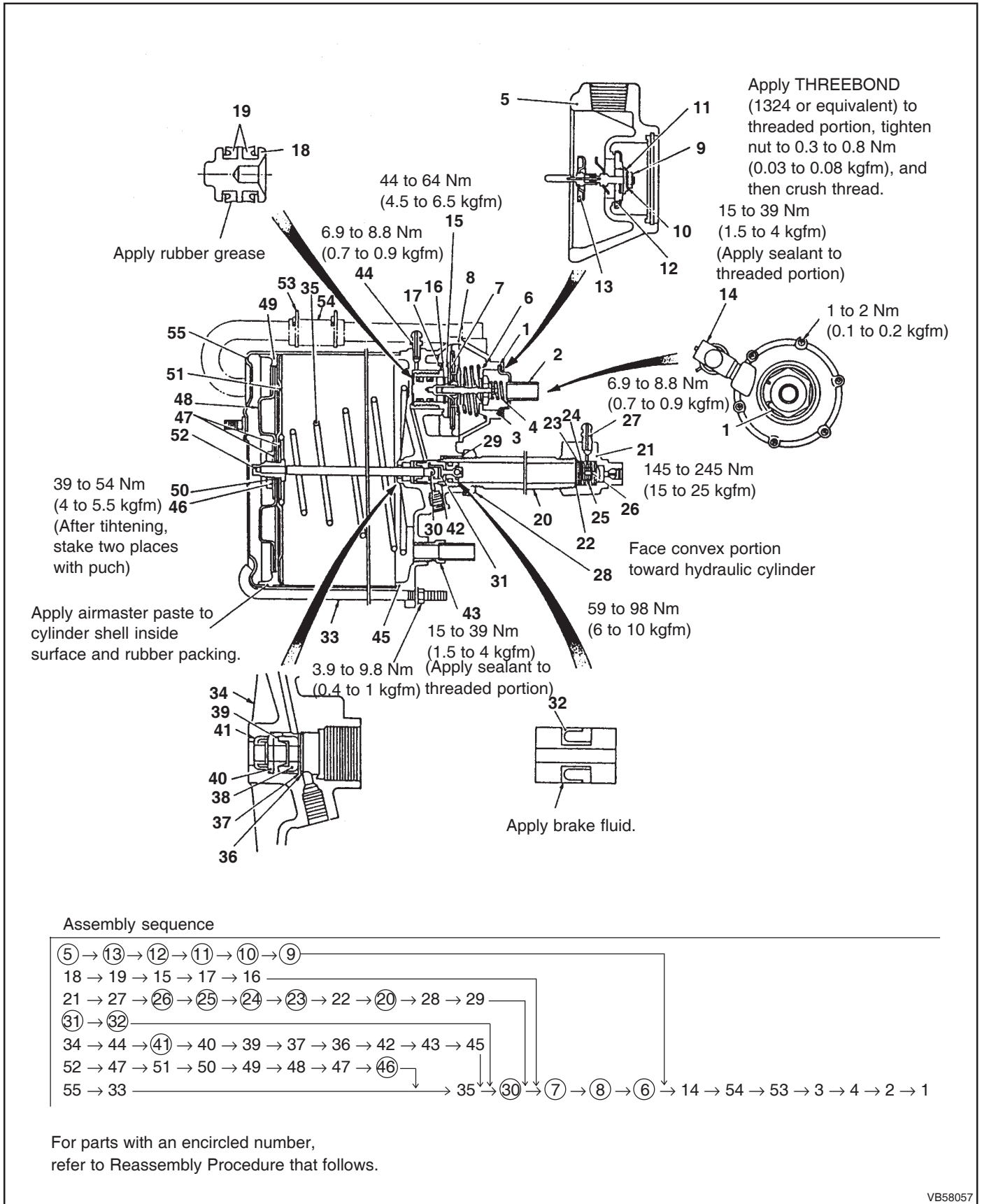

Reassembly Procedure

1) Installation of power piston section push rod nut

With the special tool, Ring Assembly, held in a vice, install the power piston, aligning its push rod nut with the flat portion of the ring assembly.

Install the washer, piston plate, rubber packing, piston plate and washer over the push rod and tighten the push rod nut to specified torque using the special tool, Socket.

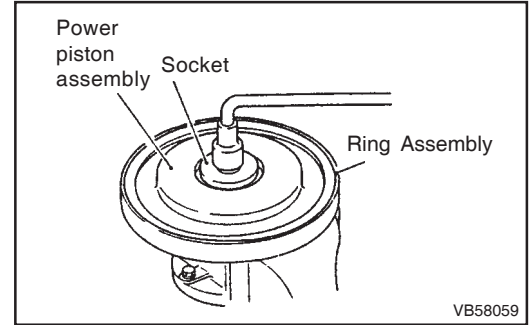

2) Installation of outlet valve retaining ring

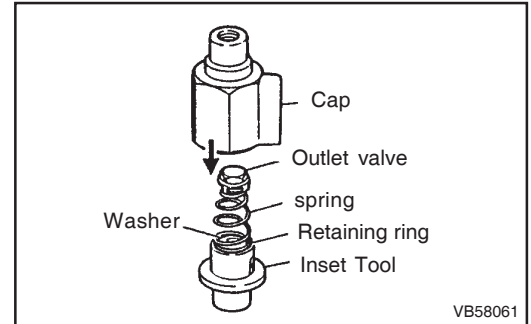

3) Insertion of cup packing into hydraulic piston

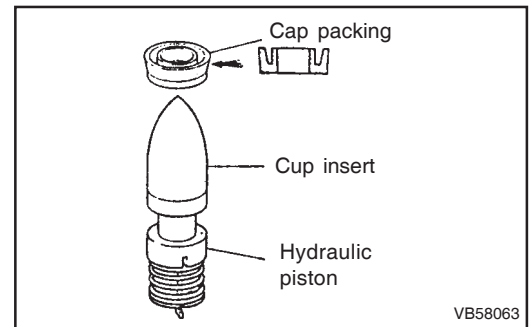

4) Installation of end plate oil seal

NOTE

When installing, face the oil seal lip toward the hydraulic cylinder.

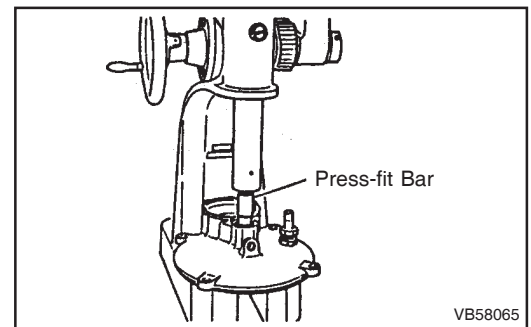

5) Installation of poppet valve to relay valve section

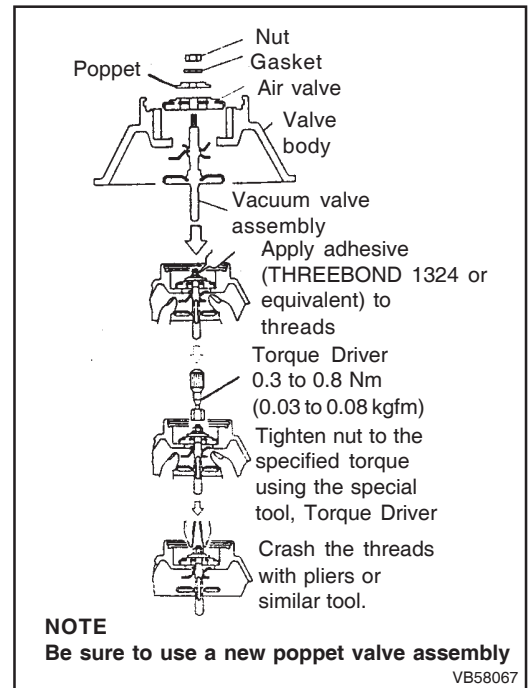

6) Installation of hydraulic piston

a) When compressed air is not used

With the return spring compressed by the special tool, Hook Clamp, and the hydraulic piston and push rod holes aligned, insert the straight pin.

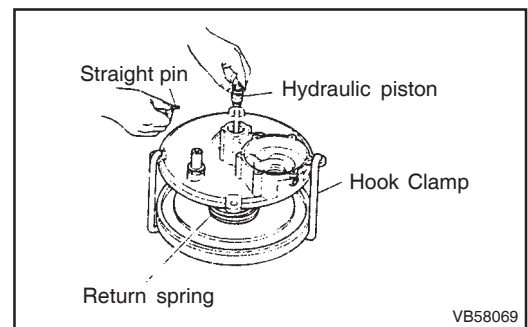

b) When compressed air is used

With the push rod pushed up by compressed air supplied through the cylinder shell pipe, align the hydraulic piston and push rod holes and insert the straight pin.

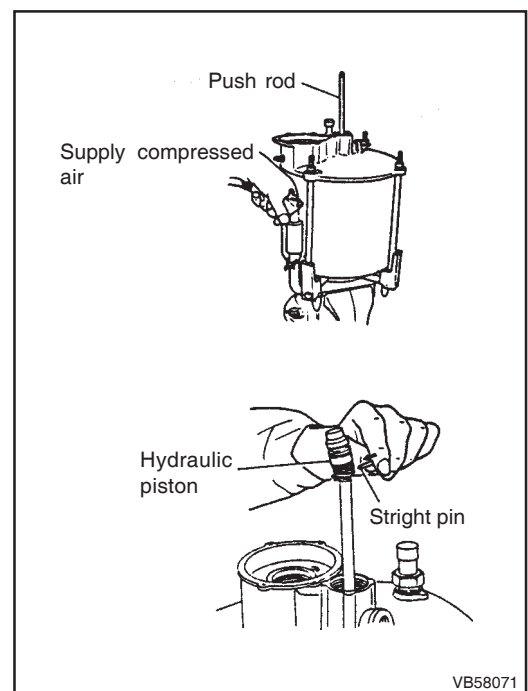

7) Installation of hydraulic cylinder

Tighten the lock nut, making sure that the cap plug and the end plate plug are 30° out of alignment.

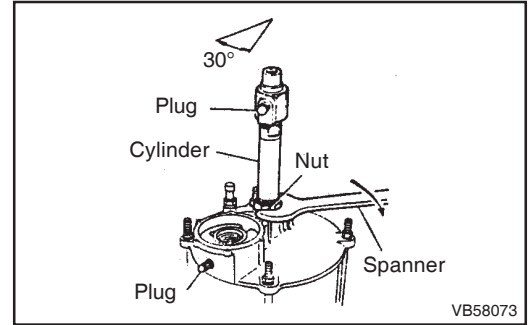

8) Installation of valve fitting

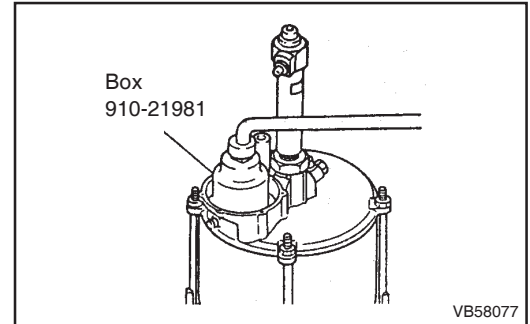

9) Installation of valve body

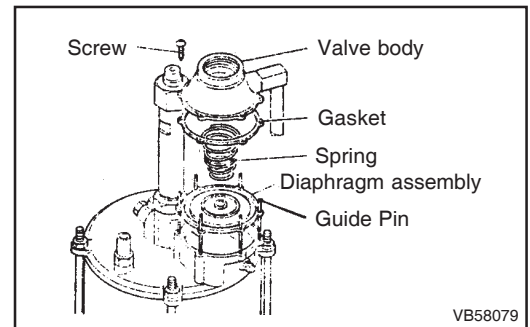

Inspection after installation

1) Performance check □

Simple Test as installed on Vehicle

This is a check method without use of instruments. If there is any doubt to the test results, check performance of individual units using a tester.

a) Overall check

With the brake booster negative pressure set at 0, depress the brake pedal as you would in ordinary braking and start the engine and run idle. If the brake pedal moves down slightly after about two or three seconds, the brake booster is performing well.

b) Oil tightness check

With the engine running at idle, depress the brake pedal fully, if the pedal is pushed back, the hydraulic piston cup and ball check valve are not oil tight.

c) Air tightness check of poppet valve (atmospheric air valve)

With the engine running at idle, put a thread near the poppet valve atmosphere side pipe without depressing the brake pedal.

If the thread is drawn in, the poppet valve atmospheric air valve is leakly.

Then depress the brake pedal. If the thread is rapidly drawn in at the moment, the relay valve piston and poppet valve are performing well.

d) Poppet valve (vacuum valve) and rubber packing check

With the engine running at idle, depress the brake pedal. If you feel suction at your finger applied to the end of atmospheric air valve side pipe of the poppet valve, the poppet valve vacuum valve or the power cylinder rubber packing is not air tight.

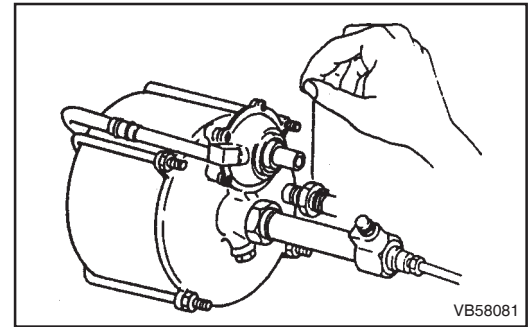

2) Performance check □□

Performance check of brake booster proper

Check the body performance in details using the Stationary Tester (Jidosha Kiki Part No.911-0020).

After all preparations for the test have been completed, bleed the fluid pressure system and test the following items.

If the results of tests show values out of the assembly standard or limit, check and replace related parts.

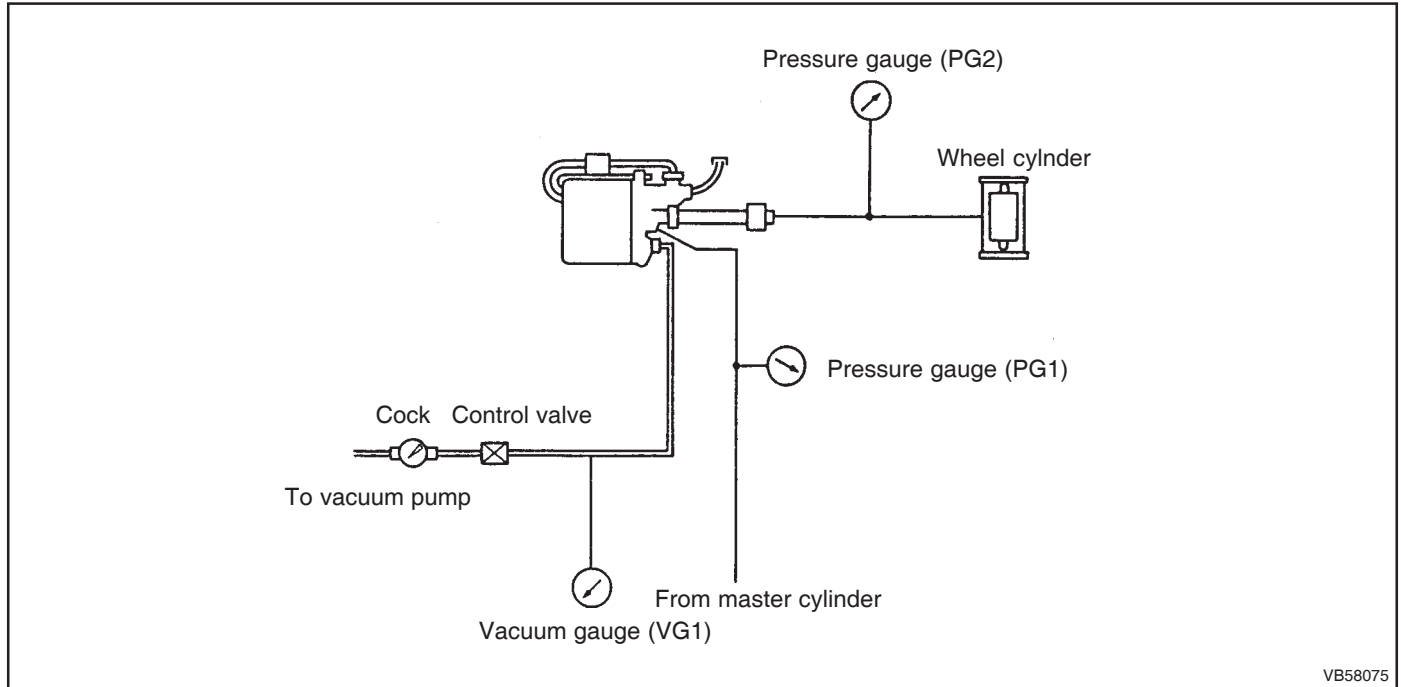

VB58075

Test item	Test condition	Assembly standard	Limit
Fluid tightness	Apply fluid pressure of 11.8 MPa (120 kgf/cm ²) (PG2) to hydraulic cylinder and measure the amount of pressure drop in 15 seconds. (In this test no vacuum state is created in brake booster.)	1470 kPa (15 kgf/cm ²) or less	-
Air tightness when not in operation	Set vacuum pressure in brke booster to 67 kPa (500 mmHg), close cock, and measure amount of vacuum pressure falls in 15 seconds. Vacuum gauge (VG1)	3.3 kPa (25 mmHg) or less	-
Operation start pressure	Set vacuum pressure in brake booster to 67 kPa (500 mmHg). Gradually apply pressure from master cylinder and read pressure indicated by mastr cylinder side pressure gauge (PG1) when pointer of vacuum gauge (VG1) swings.	125 to 225 kPa (1.3 to 2.3 kgf/cm ²)	105 to 245 kPa (1.1 to 2.5 kgf.cm ²)
Operation at full load	Set vacuum pressure in brake booster to 67 kPa (500 mmHg). Slowly depress pedal of master cylinder and read pressure indicated by hydraulic cylinder side pressure gauge (PG2) for master cylinder side pressure gauge (PG1).	1570 kPa (16 kgf/cm ²) 10.1 to 11.1 MPa (103 to 113 kgf/cm ²)	1570 kPa (16 kgf/cm ²) 9.81 to 11.4 MPa (100 to 116 kgf/cm ²)
Air tightness at full load	During operation at full load, cut off vacuum supply and read amount of vacuum pressure falls in 15 seconds thereafter. Vacuum gauge (VG1)	3.3 kPa (25 mmHg) or less	-
Residual pressure	Set pressure of master cylinder to 490 kPa (5 kgf/cm ²) (PG1), loosen air bleeder screw at end of hydraulic cylinder, release master cylinder side pressure, and read pressure indicated by wheel cylinder side pressure gauge (PG2).	78 to 125 kPa (0.8 to 1.3 kgf.cm ²)	59 to 155 kPa (0.6 to 1.6 kgf/cm ²)

SAFETY CYLINDER

Disassembly and Inspection

Deterioration of spring

Load/installed length
 NV 18 to 22 N
 (1.81 to 2.21 kgf)/48
 L 15 N (1.5 kgf)/48

Cylinder to piston clearance
 BD 30
 NV 0.06 to 0.12
 L 0.17

Disassembly sequence

1. Cylinder cap
2. Cylinder packing
3. Spring
4. Piston
5. Check bolt nut
6. O-ring
7. Packing
8. Check bolt
9. Boot
10. Snap ring
11. Stopper
12. Bleeder
13. O-ring
14. Cylinder

BD ... Basic Diameter
 NV ... Nominal Value
 L ... Limit

Repair kit:
 Safety cylinder kit

o Corroded metal stopper
o Rust, damage on inner surfaces

VB58083

Reassembly

235 to 265 Nm
 (24 to 27 kgfm)

Assembly sequence

```

            14 → 11 → 10 → 9 → 8 → 7 → 4 → 3 → 2 → 1
            12 → 13
            5 → 6
            
```

NOTE
 Before reinstallation, apply brake fluid to cylinder bore and piston external surfaces.

VB58085

WHEEL BRAKE

Front wheel brake

1) Brake hose

To remove the brake hose, first disconnect the bracket side end (frame side) and then disconnect the wheel brake side end. To install, reverse this procedure.

NOTE

Install the brake hose taking care not to twist it.

2) Removal and installation

3) Disassembly, inspection and correction

NOTE

1. Wash the disassembled metallic parts in a cleaning solvent or gas oil. Wash the rubber parts in an alcohol solution (do not immerse for more than 30 seconds) and blow dry with compressed air.
2. Never immerse the rubber parts in a cleaning solvent or gas oil.
3. If the brake lining required replacement, replace as a brake lining kit.

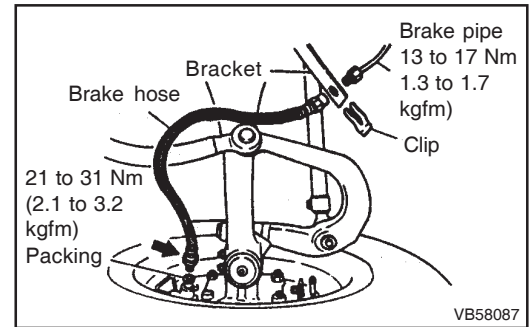

Deterioration of spring

Load/installed length
NV 325 N (33 kgf)/192

L Springhaving gaps between coils and between coil and cover

Cracks, burn, damage

Thickness of lining
NV 12

L 15

Score or uneven wear of inside surface

I.D.	Cylindricity
NV 320	NV 0.05
L 322	L 0.2

Disassembly sequence

1. Pipe assembly
2. Pipe assembly
3. Hose and pipe joint assembly
4. Return spring
5. Split pin
6. Nut
7. Washer A
8. Brake shoe assembly
9. Wheel cylinder
10. Backing plate assembly

For parts with an encircled number, refer to Disassembly Procedure that follows.

NOTE

1. For repair limit of the brake drum, see 3) Correction of drum, Disassembly Procedure.
2. The shoe squareness adjust bolt of the backing plate maintains shoe squareness. Do not loosen this bolt.

VB58089

Disassembly procedure

1) Removal of return spring

Using a screwdriver, remove the return spring.

2) Replacement of brake lining

a) Service points of removal

When drilling out the brake lining rivets, use care not to enlarge or damage the brake shoe hole by the drill.

b) Service points of installation

- o Rivet starting from the center portion and working toward the ends. Make sure that no gap is produced between the shoe and lining.
- o Stake the rivets to 17 to 19 kN (1700 to 1900 kgf).
- o Select the lining according to the operating conditions of the vehicle. Use linings of the same size and paint color on right and left wheels of the same axle.
- o After relining, check contact with the drum inside and correct poor contact if any. Correct the lining as incorporated into the wheel and brake assembly.

3) Correction of drum

If the drum has a cylindricity of 0.2 mm or poorer or is scratched, correct to the repair limit. After machining, use an oversize lining.

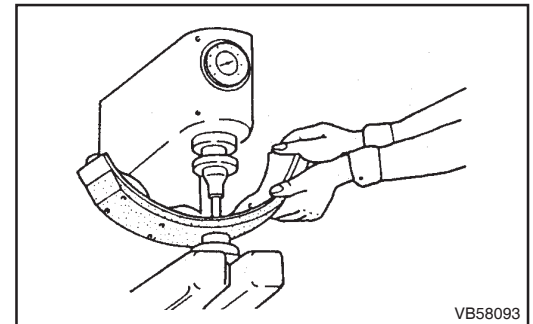
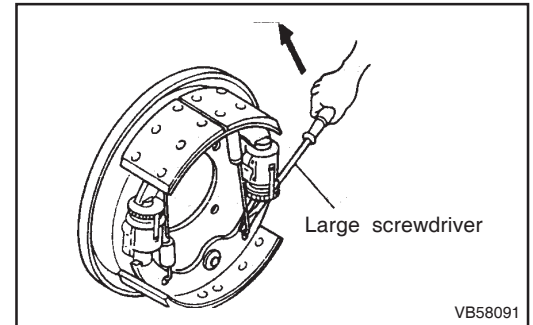

Drum diameter	Repair limit	Service limit
320	321	322

- 4) Reassembly
 - a) Vehicle with 320 drum brake

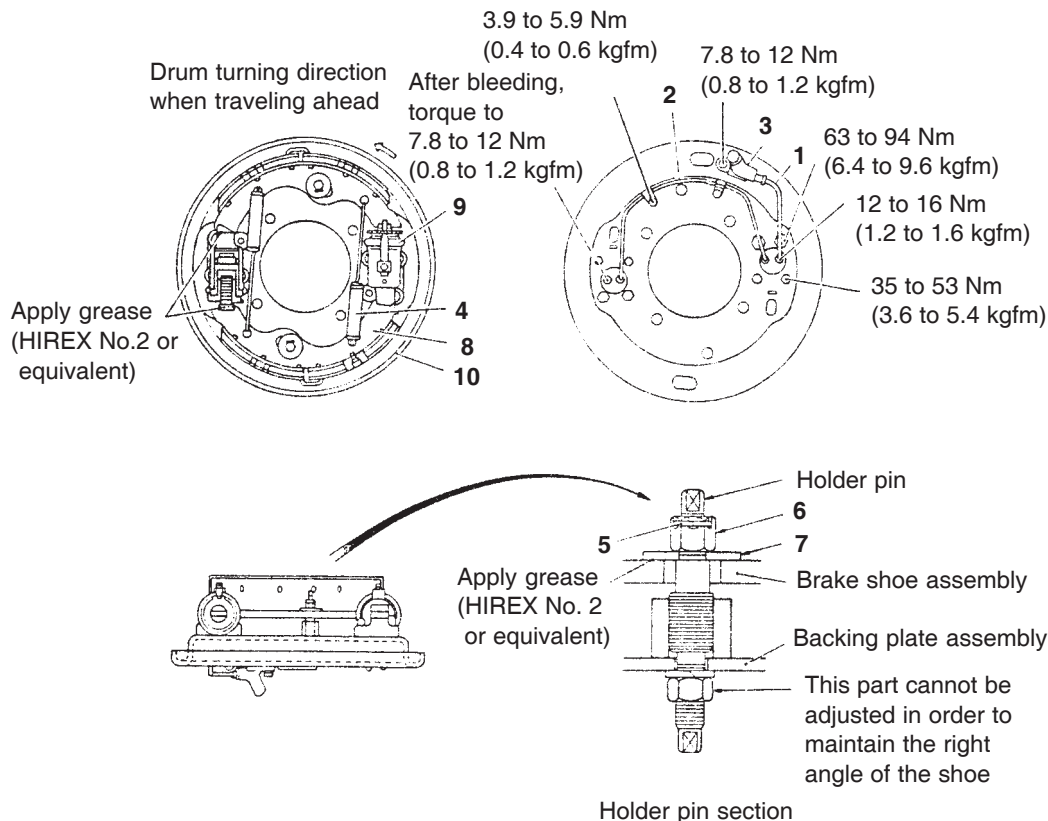

Assembly sequence

10→9→3→2→1→8→7→6→5→④

For parts with an encircled number, refer to Reassembly Procedure that follows.

NOTE

Keep the lining surface free of oil and grease.

Installation of Brake Shoe Assembly

Fit the nut over the holder pin and tighten until the washer A is forced lightly against the stepped portion of the holder pin. Then back off the nut (0 to 60°) to the split hole of the first fit of the holder pin and lock with a split pin. Then, install the return spring.

VB58095

Reassembly procedure

- 1) Wheel cylinder installation position

The wheel cylinder body has an identification mark to indicate the installation position. Install according to the mark

Identification mark	Installation position
RF	Right front wheel
RR	Right rear wheel
LF	Left front wheel
LR	Left rear wheel

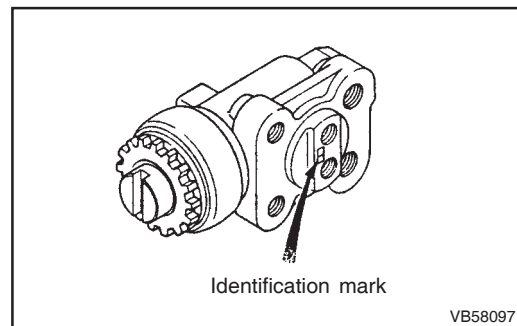

VB58097

- 2) Installation of return spring
Using a screwdriver, fit the return spring.

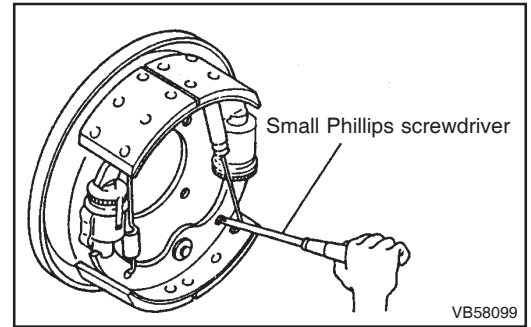

- 3) Adjustment of holder pin

This adjustment is not required under normal circumstances. When the holder pin has been replaced and when the brake drags despite the adjustment of correct brake shoe clearance performed immediately after the lining has been replaced, the following adjustment is necessary as brake shoe squareness is probably incorrect.

- Accessing from the back of backing plate, turn the wheel cylinder adjust so that the O.D. of brake shoe assembly measures about 319 ± 0.5 mm. Also, centrally align the brake shoe assembly.
- Referring to Front Axle, install the wheel hub and brake drum.

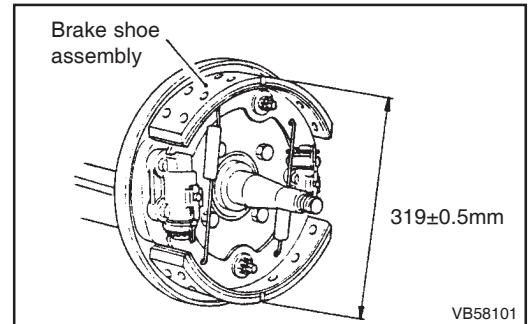

NOTE

If the wheel hub and brake drum is hard to install all the way into position because of the brake shoe assembly excessively tilted, turn the holder pin to correct the tilt.

- Bleed the brake system of air.
- Through the check hole, insert a 0.2-mm feeler gauge into the space between the drum and lining. Then, turn the wheel cylinder adjuster in the direction indicated by the stamped arrow to expand the brake shoe assembly so that the feeler gauge cannot be removed easily.
- Loosen the nut on the holder pin. Turn the holder pin clockwise or counterclockwise so that the feeler gauge can easily be removed and inserted.
- Repeat steps d) and e) until the feeler gauge becomes hard to remove.
- Lightly depress the brake pedal two to three times to center the brake shoe assembly.
- Repeat steps d) and e) again.
- Remove the feeler gauge when it contacts the lining to the full width. Then, reinsert it and adjust the holder pin so that you feel the gauge binding in the depths. Now, tighten the nut to specification.

NOTE

In step h), when the feeler gauge becomes hard to remove or insert indicates that the gauge contacts the lining to the full width.

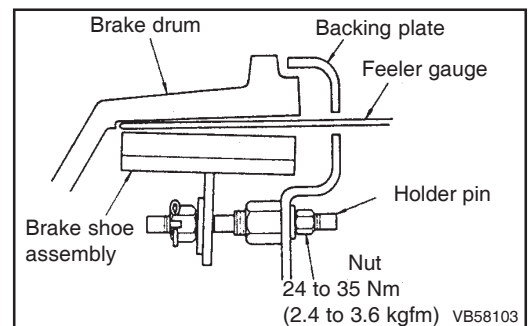

Front wheel cylinder

1) Disassembly and inspection

Clearance between piston and body	
BD	34.93
NV	0.03 to 0.09
L	2

Disassembly sequence

1. Adjuster stopper
2. Adjuster
3. Adjuster screw
4. Boot
5. Piston
6. Piston cup
7. Bleeder screw
8. Body
9. Backup ring

BD ... Basic Diameter
 NV ... Nominal Value
 L ... Limit

Repair kit:
 Wheel cylinder kit

VB58105

2) Reassembly

Apply rubber grease
 (NIGLUBE RX-2 or
 equivalent).

Assembly sequence
 9→8→6→5→4→3→2→1

VB58107

Rear wheel brake

1) Brake hose

To remove the brake hose, first disconnect the bracket side end (frame side) and then disconnect the rear axle housing side end. To install, reverse this procedure.

NOTE

Install the brake hose taking care not to twist it.

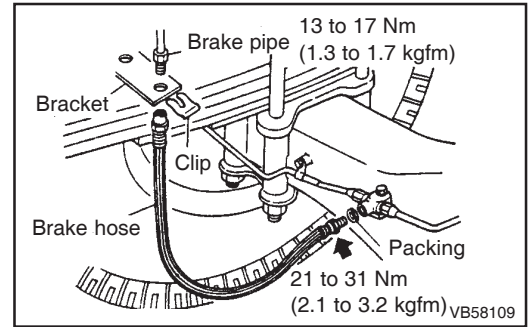

2) Removal and installation

3) Disassembly, inspection and correction

NOTE

1. Wash the disassembled metallic parts in a cleaning solvent or gas oil. Wash the rubber parts in an alcohol solution (do not immerse for more than 30 seconds) and blow dry with compressed air.
2. Never immerse the rubber parts in a cleaning solvent or gas oil.
3. If the brake lining required replacement replace as a brake lining kit.

Deterioration of spring

Load/installed length
 NV 390 N (40 kgf)/217
 L Springhaving gaps
 between coils and between
 coil and cover

Cracks, burn, damage

Thickness of lining
 NV 12
 L 5

**Score or uneven wear
of inside surface**

I.D.	Cylindricity
NV 320	NV 0.05
L 322	L 0.2

Disassembly sequence

1. Pipe assembly
2. Return spring
3. Split pin
4. Nut
5. Washer A
6. Brake shoe assembly
7. Wheel cylinder
8. Wheel cylinder cover
9. Backing plate assembly

For parts with an encircled number, refer to Disassembly Procedure that follows.

NOTE

1. For the repair limit of the brake drum, see 3) Correction of drum, Disassembly Procedure.
2. The shoe squareness adjust bolt of the backing plate maintains shoe squareness. Do not loosen this bolt

NV ... Nominal Value
 L ... Limit

VB58111

Disassembly procedure

- 1) Removal of return spring
Using a screwdriver, remove the return spring.
- 2) Replacement of brake lining
 - a) Service points of removal
When drilling out the brake lining rivets, use care not to enlarge or damage the brake shoe hole by the drill.
 - b) Service points of installation
 - o Rivet starting from the center portion and working toward the ends. Make sure that no gap is produced between the shoe and lining.
 - o Stake the rivets to 17 to 19 kN (1700 to 1900 kgf).
 - o Select the lining according to the operating conditions of the vehicle. Use linings of the same size and paint color on right and left wheels of the same axle.
 - o After relining, check contact with the drum inside and correct poor contact if any. Correct the lining as incorporated into the wheel and brake assembly.

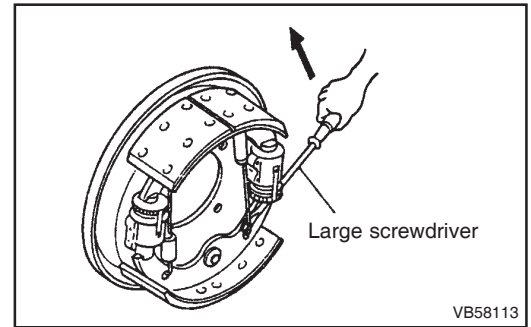

VB58113

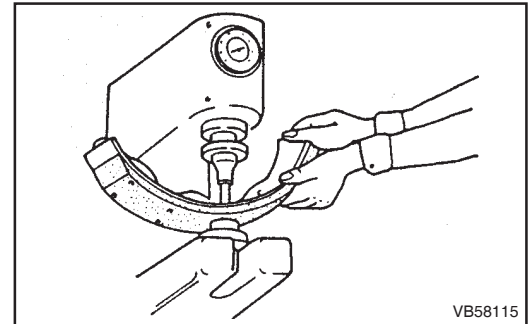

VB58115

NOTE

On FL series, never use the lining other than the standard lining. (LP1023)

- 3) Correction of drum
If the drum has a cylindricity of 0.2 mm or poorer or is scratched, correct to the repair limit. After machining, use an oversize lining.

Drum diameter	Repair limit	Service limit
320	321	322

4) Reassembly

a) Vehicle with 320 drum brake

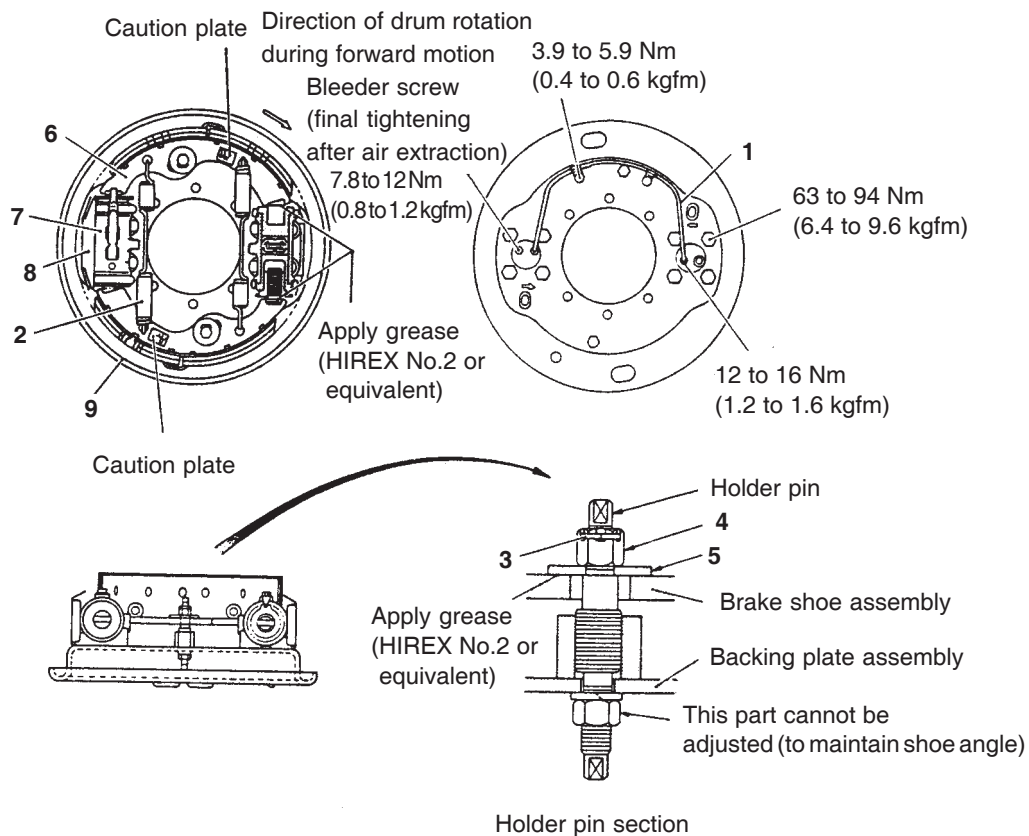

Assembly sequence

9→8→8→1→6→5→4→3→④

For parts with an encircled number, refer to Reassembly Procedure that follows.

NOTE

Keep the lining surface free of oil and grease.

Installation of Brake Shoe Assembly

Fit the nut over the holder pin and tighten until the washer A is forced lightly against the stepped portion of the holder pin. Then back off the nut (0 to 60°) to the split hole of the first fit of the holder pin and lock with a split pin. Then, install the return spring.

Reassembly procedure

1) Installation of return spring (drum dia. 320)

Catch the shorter hook of the return spring onto the brake shoe assembly as shown on the caution plate attached to the brake shoe assembly. Catch the other hook with a small Phillips screwdriver and insert the tip of the screwdriver into the return spring mounting hole in the brake shoe assembly. Then, pry the hook into the hole.

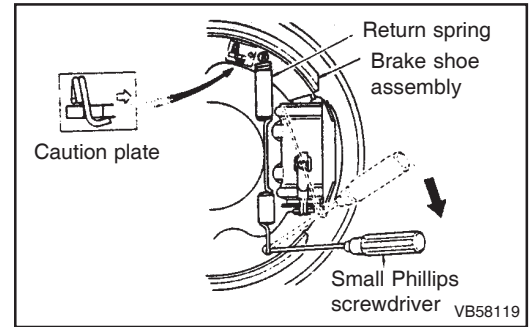

2) Adjustment of holder pin <Vehicles with 320 drum brake only>

This adjustment is not required under normal circumstances. When the holder pin has been replaced and when the brake drags despite the adjustment of correct brake shoe clearance performed immediately after the lining has been replaced, the following adjustment is necessary as brake shoe squareness is probably incorrect.

- a) Accessing from the backing plate, turn the wheel cylinder adjuster so that the O.D. of brake shoe assembly measures about 319 ± 0.5 mm. Also, centrally align the brake shoe assembly.
- b) Install the wheel hub and brake drum.

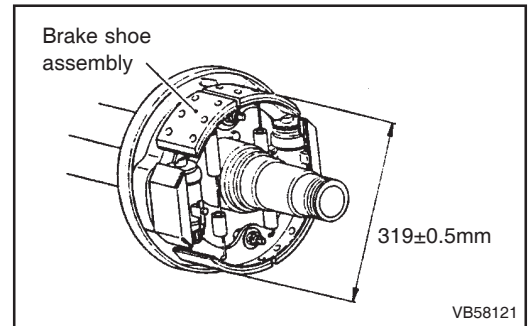
**NOTE**

If the wheel hub and brake drum is hard to install all the way into position because of the brake shoe assembly excessively tilted, turn the holder pin to correct the tilt.

Rear wheel cylinder

1) Disassembly and inspection

BD ... Basic Diameter
 NV ... Nominal Value
 L ... Limit

Repair kit:
 Wheel cylinder kit

Clearance between piston and body
 BD 36.51
 NV 0.03 to 0.09
 L 0.2

Disassembly sequence

1. Adjuster stopper
2. Adjuster
3. Adjuster screw
4. Boot
5. Piston
6. Piston cup
7. Piston cup
8. Piston
9. Bleeder screw
10. Body
11. Backup ring

58AR38-1

2) Reassembly

0.6~1.0kg·m

Apply rubber grease (RG-4 or equivalent) to internal surface of cylinder and periphery of piston

Assembly sequence

11→10→8→6→5→4→3→2→1

Section A-A(Rear)

58AR38-2

Inspection and Adjustment after Installation

Shoe clearance adjustment

Before adjustment, referring to Item (2).

- 1) Jack up the axle and check to ensure that the hub is free from looseness.
- 2) Remove the adjusting hole plug from the backing plate. Using Shoe Gap Adjuster, turn the adjuster of the wheel cylinder in the direction of an arrow stamped on the backing plate, until the tire drags a little when turned by hand.

NOTE

1. The arrow in stamped on the area near the adjusting hole plug of the backing plate.
2. Make adjustment at two places on each wheel.

- 3) After depressing the brake pedal several times, make sure that the tire drags a little when turned by hand. If the tire turns lightly repeat the above procedures beginning with step 2).
- 4) Back off the adjuster of the wheel cylinder 8 to 9 notches in the direction opposite to that of the arrow.

NOTE

Make adjustment at two places on each wheel.

- 5) Turn the tire by hand and make sure that the tire does not drag. If the tire drag, repeat the procedure beginning with steps (2).
- 6) Remove the check hole plug from the backing plate. Insert a filler gauge between the brake drum and the lining. Make sure that the clearance when slight resistance is left while withdrawing the gauge is 0.2 mm.

NOTE

Make the check at two places on each wheel.

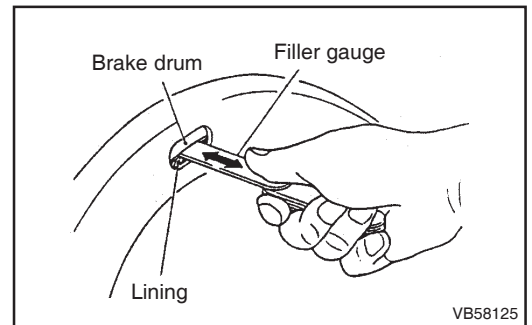
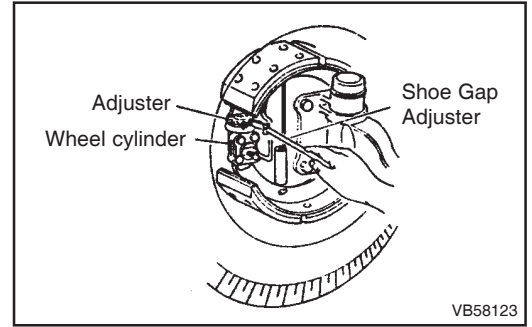

Replacement of brake fluid and bleeding of brake system

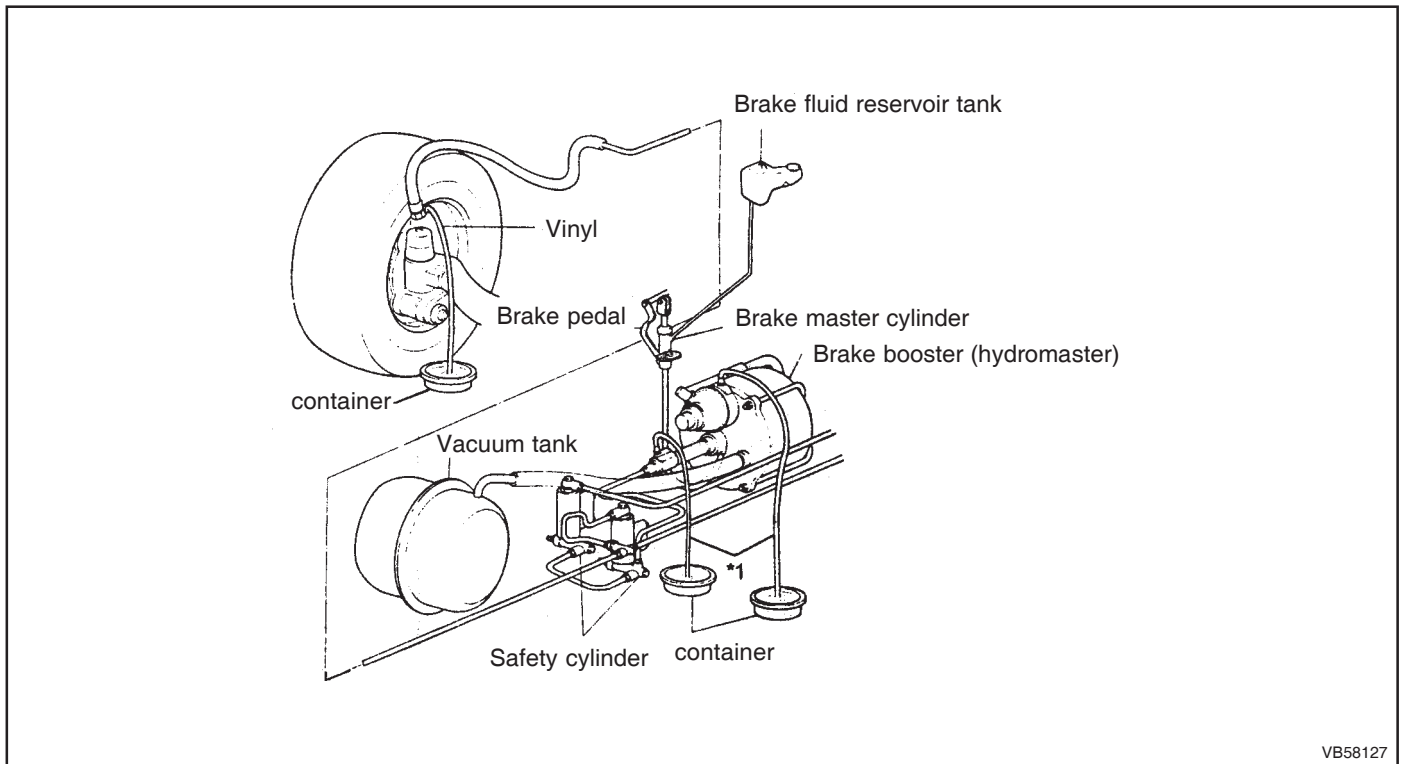

VB58127

NOTE

Before replacing the brake fluid or bleeding the brake system, stop the engine and depress the brake pedal several times to reduce the negative pressure in the vacuum tank until warning lamp lights.

- 1) Replacement of brake fluid
 - a) Mount the special tool, vinyl Pipe to the bleeder screw of the wheel cylinder.
 - b) Loosen the air bleeder and depress the brake pedal several times until brake fluid ceases to run out.
 - c) Mount a vinyl pipe to the air bleeder of the brake booster.
 - d) Loosen the air bleeder and depress the brake pedal repeatedly several times until there is no more brake fluid in the reservoir tank and brake fluid ceases to run out from the air bleeder.
 - e) Bleed the clutch system by the same procedures.
 - f) While pouring in fresh brake fluid (fluid in fully-enclosed container free from water, dust, etc.) into the reservoir tank, depress the pedal repeatedly until the fluid in the brake system is replaced with the fresh fluid.

NOTE

1. Use brake fluid that conforms to SAE J1703f or FMVSS No. 116 DOT3. Never mix different kinds of brake fluid as such a mixture can cause brake drag.
2. If the fluid in the brake system is replaced with fresh fluid, the fluid that runs out will change in color. Keep close watch on the fluid that runs out.

At the time, thread the air bleeder valve of the safety cylinder back until the valve is lightly blocked by the stopper.

- g) Tighten all the air bleeders, fill the reservoir tank with the specified quantity of brake fluid, and bleed the brake and clutch.

2) Bleeding of brake system

- a) Make sure that the brake fluid in the fluid reservoir tank is at H level.

NOTE

The brake fluid level will fall during bleeding operation. Perform bleeding operation while pouring fresh brake fluid (which is kept in the fully-enclosed container and is free of dust, water, etc.) into the fluid reservoir tank.

- b) Tighten the front and rear check bolts of safety cylinder to block up the fluid passages from the brake booster.
- c) Install one end of transparent vinyl pipe to the air bleeder of hydraulic cylinder of brake booster and place the other end of the vinyl pipe in the container filled with brake fluid.
- d) Depress the brake pedal all the way several times. Then, with the pedal kept depressed, loosen the air bleeder to bleed air together with brake fluid. Immediately after bleeding, close the air bleeder and release the pedal.
- e) Repeat this operation until there is no more air bubble in brake fluid flowing out from the air bleeder.
- f) Bleed air from the air bleeder of relay valve of brake booster in the same manner as described in d) and e).
- g) Return the front check bolt of safety cylinder to the original position and back off the front air bleeder valve until it comes in contact with the stopper.
- h) Bleed air from the air bleeder of front wheel cylinder in the same manner as described in d) and e).

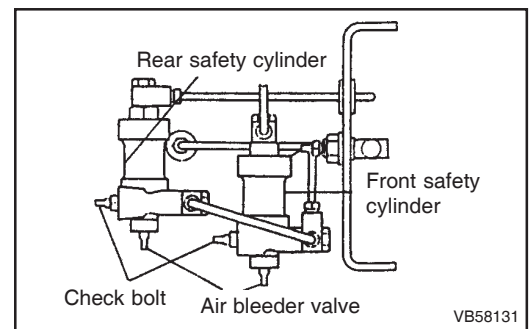
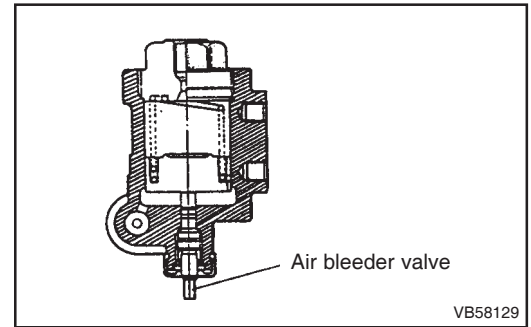

- i) Depress the brake pedal all the way repeatedly (Depress the pedal 5 to 6 times continuously until the pedal cause a reaction. Then, depress the pedal three times repeatedly). Repeat the air bleeding of master cylinder until there is no more air bubble produced in fluid reservoir tank. (It takes 4 to 8 seconds between releasing of pedal and formation of air bubble at the surface of fluid in the fluid reservoir tank.)
- j) Return the rear check bolt of safety cylinder to the original position and back off the rear air bleeder valve until it comes in contact with the stopper.
- k) Bleed air from the air bleeder of rear wheel cylinder in the same manner as described in d) and e).
- l) Make sure that wheel brake shoe clearance has been adjusted to 0.2mm. Then, depress the brake pedal with a force of about 590N (60 kgf) and make sure that a clearance of 65mm or more is provided between the pedal and toeboard.
- m) If a pedal-to-toeboard clearance is not within the nominal value, bleed air again from the following parts in the order of mention until the clearance is within the nominal value.
 - 1) Brake booster relay valve
 - 2) Front wheel cylinder
 - 3) Brake booster hydraulic cylinder
 - 4) Rear wheel cylinder
- n) After completion of air bleeding, tighten the front and rear air bleeder valves until they come in contact with the respective stoppers.
- o) Check the fluid level in the fluid reservoir tank and add brake fluid until the fluid reach the H level.
- p) Start the engine and increase negative pressure until warning lamp goes out. Then, depress the brake pedal and check each part for fluid leaks.

Tightening of brake pipes

Mouthpiece shape	Pipe diameter (mm)	Thread diameter (mm)	Pitch (mm)	Tightening torque
	4.76	10	1.0	12 to 16 Nm (1.2 to 1.6 kgfm)
	6.35	12	1.0	19 to 25 Nm (1.9 to 2.6 kgfm)

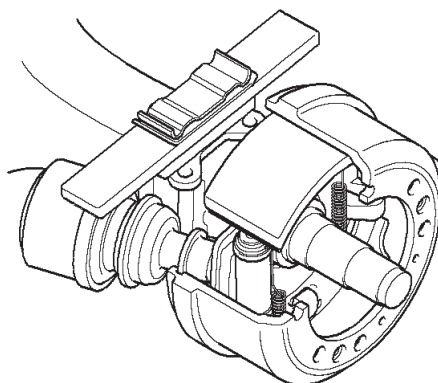
FULL AIR BRAKE (WEDGE BRAKE)**General**

ATBR-700

Specification

Item	Front	Rear
Specification	360 X 160	←
Brake type	Leading & Trailing	←
Effective radius	180 mm	←
Lining usable thickness	10 mm	←
Lining area	1106 cm ²	←
Brake chamber	Type 12	
Spring chamber		Type 12 / 16

Schematic diagram

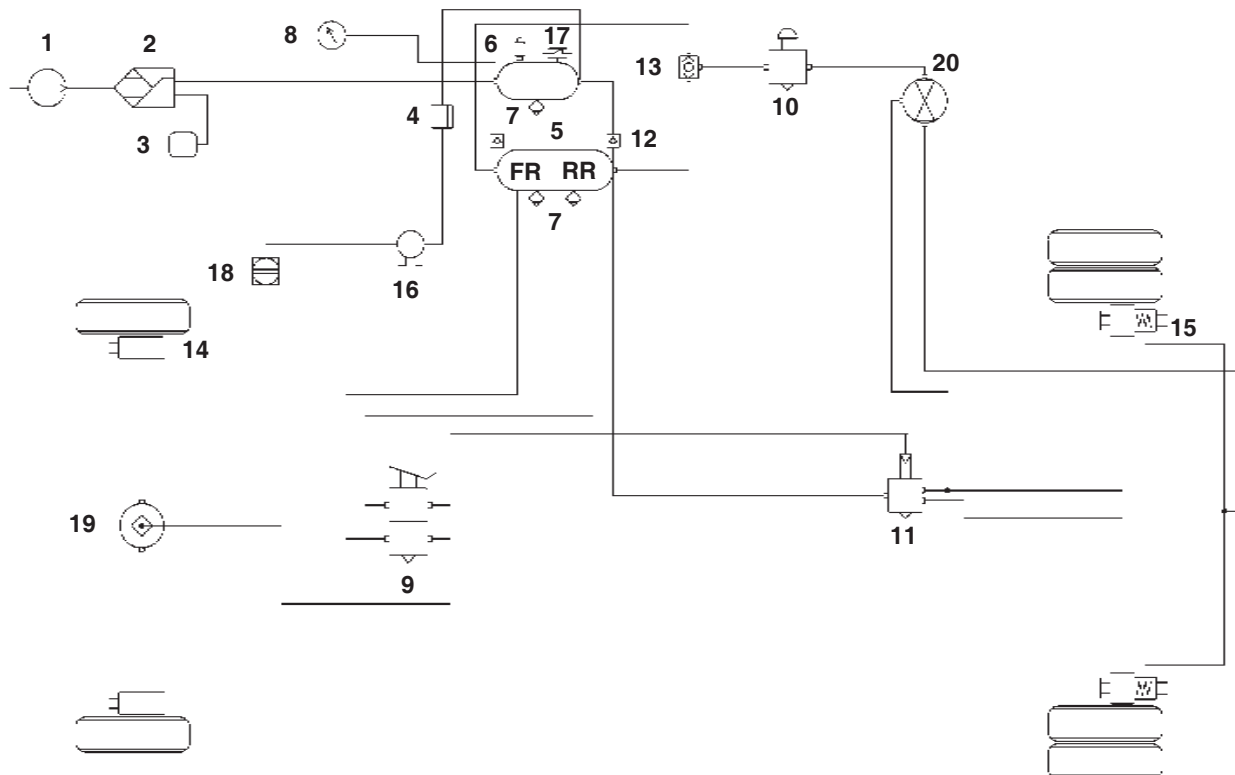

- | | | |
|-------------------------------|-------------------------|---------------------------------|
| 1. Air compressor | 8. Air gauge | 15. Brake chamber spring |
| 2. Air drier | 9. Dual brake valve | 16. Magnetic valve |
| 3. Air tank | 10. Parking brake valve | 17. Low air pressure switch |
| 4. 4-circuit protection valve | 11. R-12 relay valve | 18. Exhaust brake valve |
| 5. Air reservoir | 12. R-14 relay valve | 19. Quick release valve |
| 6. Safety valve | 13. Double check valve | 20. Quick release one way valve |
| 7. Drain valve | 14. Brake chamber | |

Description of operation

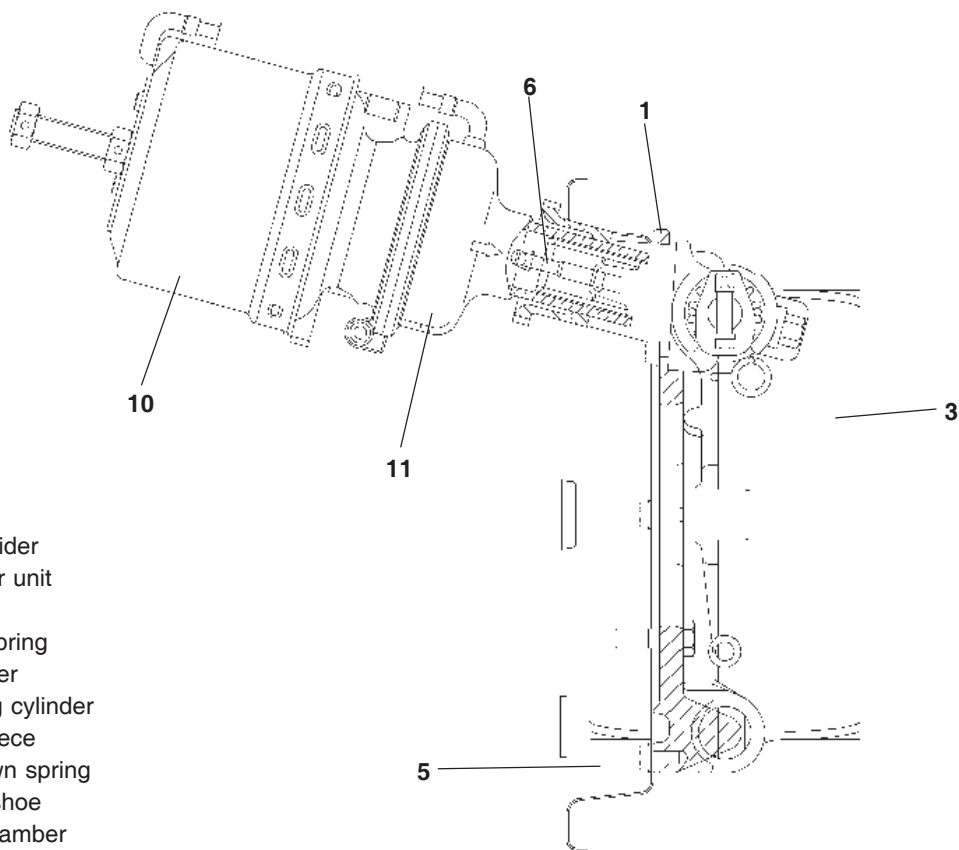
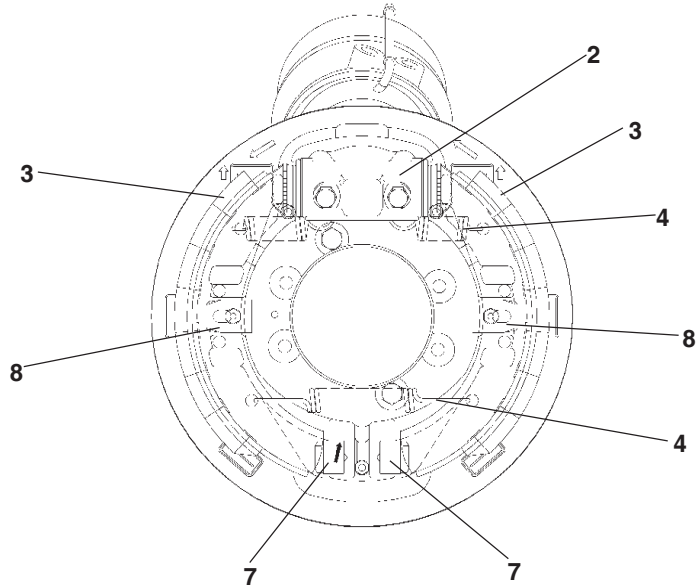

- 1. Brake spider
- 2. Expander unit
- 3. Shoe
- 4. Return spring
- 5. Dust cover
- 6. Actuating cylinder
- 7. Thrust piece
- 8. Hold-down spring
- 9. Trailing shoe
- 10. Brake chamber
- 11. Spring chamber

Brake actuation

Activation of the brake, see illustration, is by the actuation cylinder which pushes the wedge (9) down between the two cage guided rollers (11) and the pistons (12), thereby displacing them sideways and so pushing the brake shoes (3) against the brake drum. The brake drum drags the brake shoes by the forward driving direction in the turning direction, see illustration. Thereby the front brake shoe or leading shoe and the rear brake shoe or trailing shoe are supported by the thrust pieces (7) in the abutment. Both brake shoes air sliding shoes, i. e. they glide on the abutment thrust pieces (7).

The brake force ratio for the leading and trailing shoes is approximately 3:1. The brake performance in the forward and the reverse directions is virtually the same.

When the braking operation is ended the wedge (9) is pushed back to its initial position by the spring (10). At the same time the shoe return springs (4) pull the brake shoes (3) back from the brake drum and the piston (12) into the housing (2) are pushed back into the idle position.

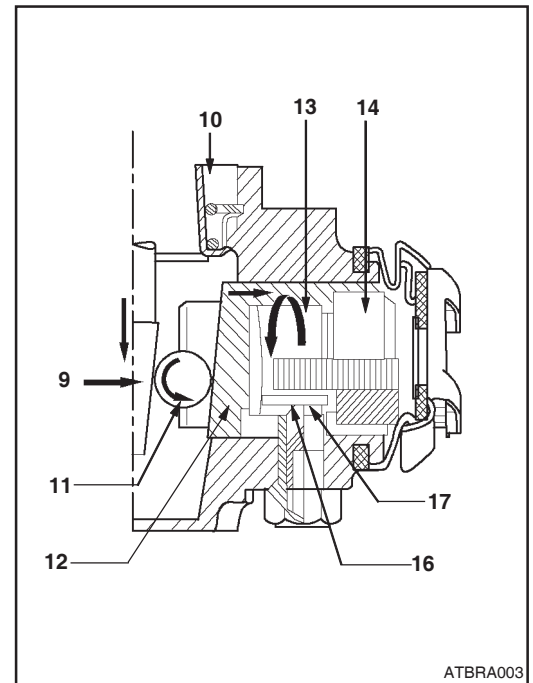

Automatic adjuster

Each piston (12) in the expander unit is provided with an automatic adjustment mechanism, which individually and continually adjusts, thereby ensuring adequate clearance between the brake drum and lining.

Upon actuating, see above, the wedge (9) is pushed between the rollers (11) against the preloaded spring (10) and the rollers (11) roll on the wedge incline and the piston (12). Thereby each piston (12) with the adjuster ring (13) and the adjuster nut (14) are pushed outwards, thus beginning the braking operation.

Through the sideways displacement of the pistons (12), the spring loaded pin (16) comes against the flank of the spiral groove (17) in the adjuster ring (13), see above, causing the adjuster ring (13) to turn by a degree corresponding to the travel of the piston (12).

By termination of the braking operation, the wedge (9) is pushed back to its initial position by spring (10). The shoe return springs (4) via the brake shoes (3) push the adjuster nut (14), adjuster ring (13), and piston (12) back into their initial position.

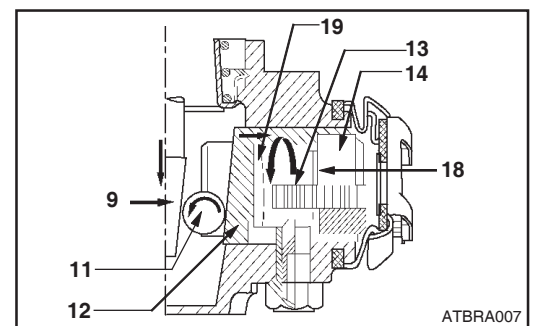
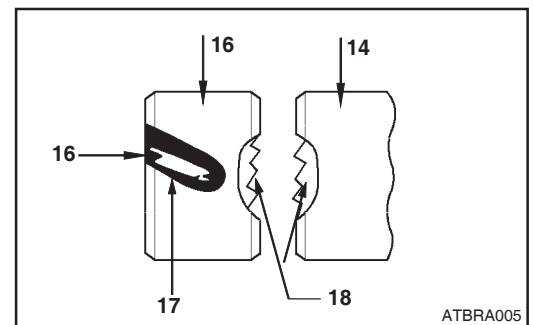

An increase in clearance resulting from lining wear in accordance with above increases the stroke of the wedge (12) and the piston (12) is pushed further outwards. Automatic adjustment occurs as soon as the rotation of the adjuster ring (13) is greater as the pitch of the serration's (18)-saw tooth from-between the adjuster ring (13) and the adjuster nut (14). Thereby the engagement of the serration's 18, loaded by curved wire spring (19), jump on tooth.

Upon releasing the brake, see right illustration, the adjuster screw (15), adjuster nut (14), adjuster ring (13) and piston (12) are pushed back by the shoe return springs (4).

The pin (16) is then pushed against the flank of the spiral groove (17) causing the adjuster nut (14) and the adjuster ring (13) to turn by a degree corresponding to the tooth pitch.

Through the thread in the adjuster nut (14), the adjuster screw (15) moves outwards thereby compensating the lining wear.

The adjuster screw (15) is fixed by leaf spring (31) and the brake shoe (3).

The optimized tooth pitch of the serration's (18) provide adjustment in very small-almost infinitesimal-uniform steps of 0.03 mm

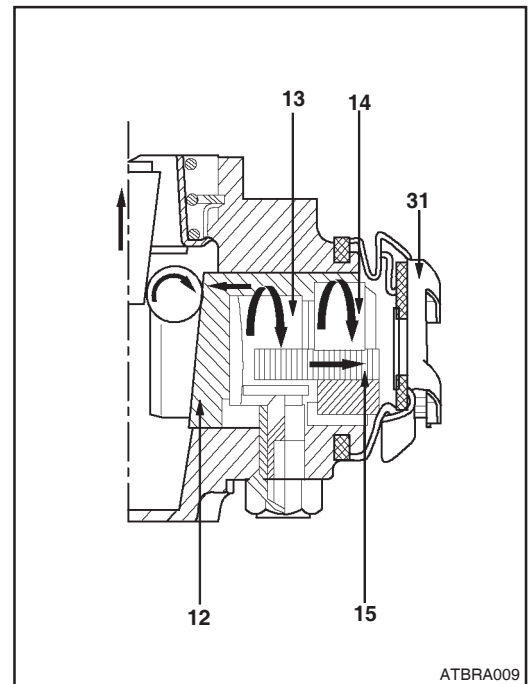

Installation

Expander unit

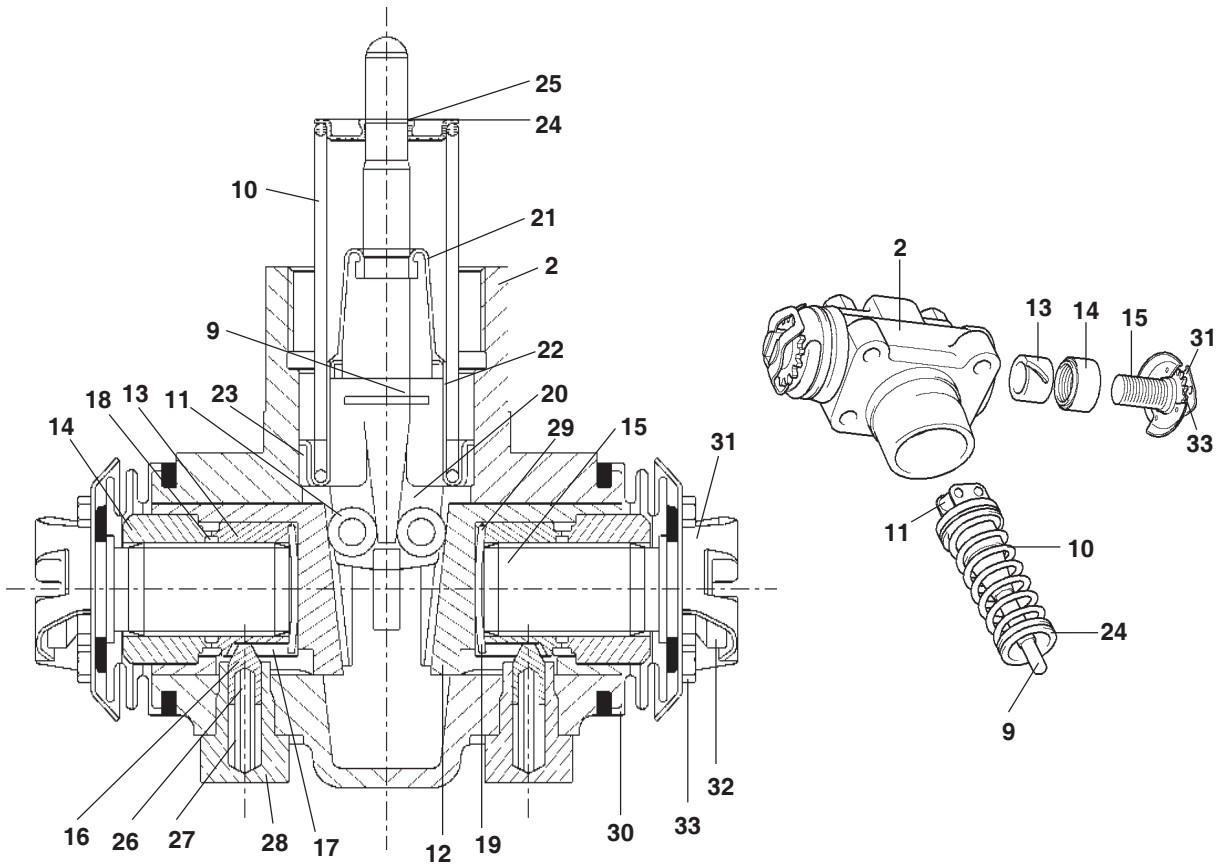

- | | |
|------------------------|-----------------------------|
| 2. Housing | 21. Roll below |
| 9. Wedge | 22. Spring retainer |
| 10. Pressure spring | 23. O-ring |
| 11. Roller | 24. Spring retainer |
| 12. Piston | 25. Snap ring |
| 13. Adjuster ring | 26. Pressure spring (long) |
| 14. Adjuster nut | 27. Pressure spring (short) |
| 15. Adjuster screw | 28. Spigoted screw |
| 16. Pin | 29. Washer |
| 17. Spiral groove | 30. Protective cap |
| 18. Serration | 31. Leaf spring |
| 19. Curved wire spring | 32. Concave seat |
| 20. Roller cage | 33. Toothed wheel |

1. Dissambly is the reverse of installation.
2. Fasten cover 5 to brake spider 1 with M8 bolts.

Tightening torque 22±2Nm.

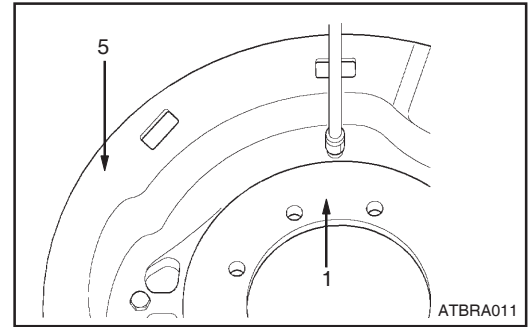

3. Set hold-down springs 8 and so that they are against the brake spider 1, and fasten with screw with hexagonal recessed hole M10 and washer.

Tightening torque 70±5Nm.

NOTE

- ? The opening of the hold-down spring must face brake shoe.

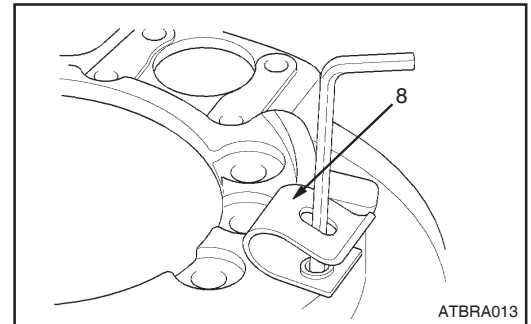

4. Install thrust pieces 7 in brake spider 1.

NOTE

- ? **Lubricate thrust pieces before installation. ○**
The plane surface of the thrust pieces and the brake spider must be non-lubricated
- ? The thrust piece with the angled shoe abutment (arrow) must be fitted to the leading shoe side.
The slope of the abutment must point towards the centre of the brake.
- ? The thrust piece with the straight shoe abutment must be fitted to the trailing shoe.

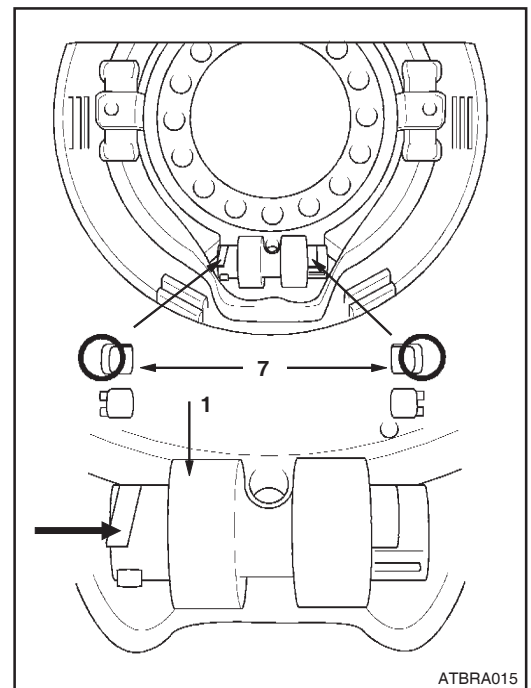

5. Moisten seat "Z" before installation, point 4.
Set expander unit 2 in the brake spider 1, and fasten with M12 bolts.

Tightening torque $135 \pm 11 \text{Nm}$.

NOTE

- ? **The opening of the leaf spring 31 must face to the centre of the brake.**
? **Head expander dimension "S" see below illustration.**

6. Smear the brake shoe contact areas  of the brake spider with grease.

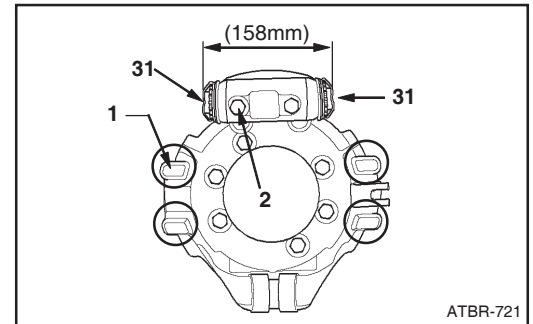
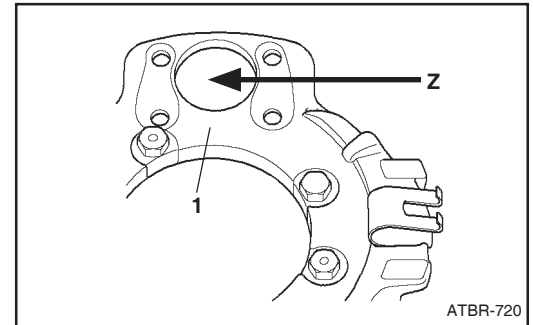

7. Place the brake shoes 3 on the brake spider 1, and slide them under the hold-down springs 8.

NOTE :

- ? **Before assembly smear the brake shoe contact areas and the shoe webs in the area of the hold-down springs with  grease.**

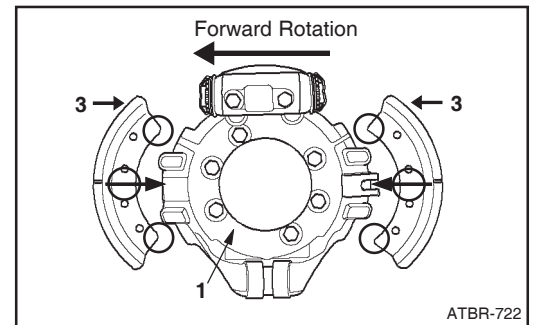

8. Fit shoe return springs 4 ensuring they are positioned correctly.

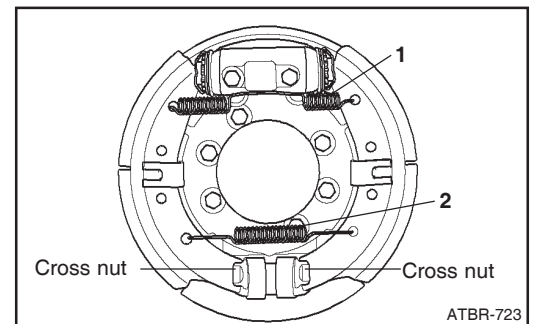

9. Fit the plugs (arrow) in the cover 5 openings.

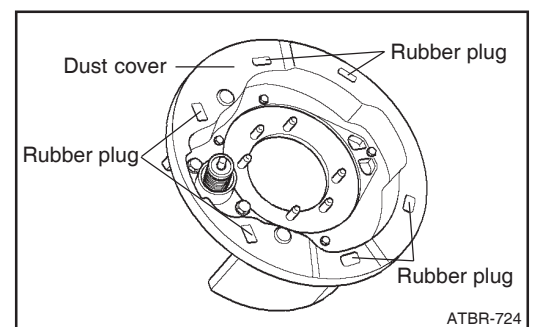

Maintenance and servicing

General remarks

Brakes and brake drums must be maintained in good working conditions to ensure safe and proper vehicle operation.

It is very important that vehicle manufacturer preventive maintenance schedules be followed and that wear parts be replaced when needed. The replacement of wear parts is described in the following sections concretely.

- **The replacement of wear parts should be axle-wise, i.e. in both brakes.**
- **Only use original spare parts from the vehicle manufacturer.**
- **Repair and service functions to be carried out only by vehicle manufacturer authorized repair facilities employing trained and qualified personal.**

Only common shop tools are necessary for the servicing and repair.

Bedding procedure

A new brake lining must be bedded in carefully in order that optimal brake effectiveness is attained. During the bedding period when the lining is not fully match with the drum, it is important to avoid heavy and continuous use of the brakes, particularly from high speeds, otherwise local overheating the lining and the drum will a consequent detraction in brake performance.

Other brake parts

All rubber parts are be renewed not later than every 2 year. This also applies to the shoe return and hold-down springs (4,8). Should the springs become damaged, e.g. over extended, corroded, over heated etc. beforehand, an earlier replacement is necessary.

Brake lining replacement

The brake lining must be renewed when its remaining thickness has reached 4,5 mm or the wear indicator step in the lining, or when they have become burned, glazed or contaminated with oil.

The visual control should be carried out in defined intervals according to duty levels, the leading shoe lining has the higher wear rate.

- **Only brake lining material which is approved by the vehicle manufacturer may be used.**
- **When replacement is necessary then all linings in the brakes or the axle must be used.**

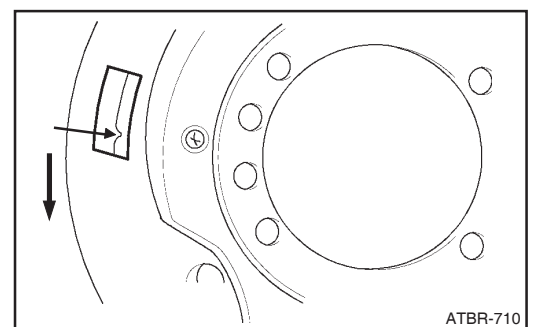

Should the drum wear be greater than the lining to drum clearance thus preventing renewal of the drum, de-adjustment of the brake shoes will be necessary. This is carried out by engaging a screwdriver, in the toothed wheel 33 via the opening (arrow) in cover 5 and turning the toothed wheel 33 in the clockwise direction until sufficient clearance is attained.

Upon renewal of the drum the resetting of the adjuster screw 15 can be done by hand.

Remove the upper and lower return spring 4 with a suitable tool (Screwdriver) and withdraw the shoes from the hold-down spring 8. De-rivet the lining by removing the peened end of the rivet with a drill tacking care not to enlarge the rivet holes in the shoe. Clean shoe and ensure it is not damaged or deformed. Fit new linings holohedral to the shoes.

Before assembly of the brake the new lining should be turned or ground to a diameter of 359,5-1,5 mm by a drum diameter of 360mm, to ensure a correct lining/drum fit and facilitate the bedding process. By overturning observe the expander unit distance "S" of 158 mm. The thickness of the standard size lining is dimensioned accordingly. If machine equipment is not available, the thinner service lining should be used.

Actuating cylinder replacement

Release lock nut and remove cylinder. Screw lock nut onto new cylinder by at least 27mm, smear cylinder thread with TEROSON-ATMOSIT. Screw the cylinder in to the thread of the expander unit until abutment and then return so far to obtain the requisite position of the air connection.

The lowest drainage hole must be open and point as near as possible vertical to the ground.

It is very important that the lowest hole remains open and the other holes are sealed with a plug.

Tighten lock nut with a tightening torque $300 \pm 20 \text{Nm}$.

During the assembly of the operation cylinder it has to be generally noted, that the free end of the wedge, which reaches out of the wedgd assembly housing is aligned according to the housing center A - see illustration and not sloping. If it is sloping it is possible, that the wedge is not in it's correct position, i.e. the rollers 11 are not in contact with the pistons 12.

To avoid mistakes during the reassembly of the operation cylinder, it is necessary to follow the work sequences and notes below.

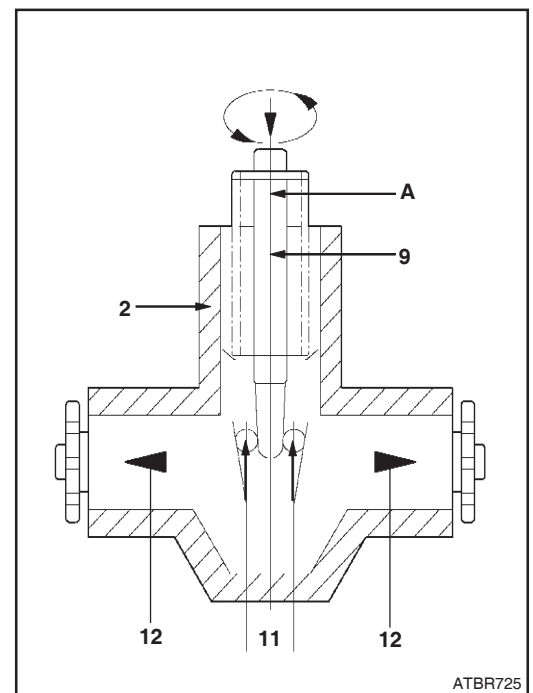
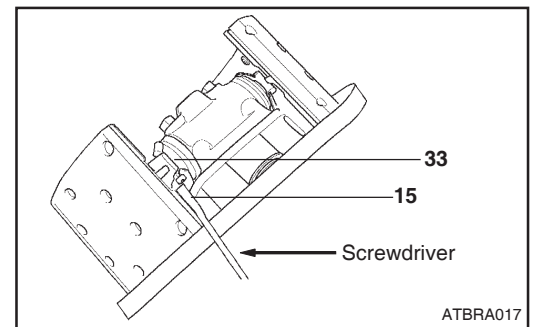

1. Align the wedge 9 with the axle A of the wedge assembly housing.
2. Push the wedge 9 in this position in the direction of the arrow into the housing 2. The rollers 11 must point in the direction of the pistons 12.
3. It has to be noted, that the rollers with their cage are not allowed to rest on the guide at the side of the housing.
4. Place the rollers carefully between the pistons. The roller cage shall not abut at the edge of the piston.

NOTE

- ? **It is possible to check the original position of the wedge. With a slight pressure of the hand rotate the outer end of the wedge. Does it move more into the housing, the correct position was not reached.**

Continuing the assembly of the brake system, i.e. fixing of the operation cylinder at the brake, it must be sure, that the wedge keeps in its original position.

Maintenance and assembly of the expander unit

The adjuster is in principle maintenance free. The expander unit should be inspected for damage and wear after not more than 2 years in service. Should damage occur beforehand, or the expander unit or adjuster mechanism fail, then these parts should be replaced completely.

In any case the rubber parts must be renewed every 2 years.

Damaged rubber parts must be replaced directly.

Exhaust Brake

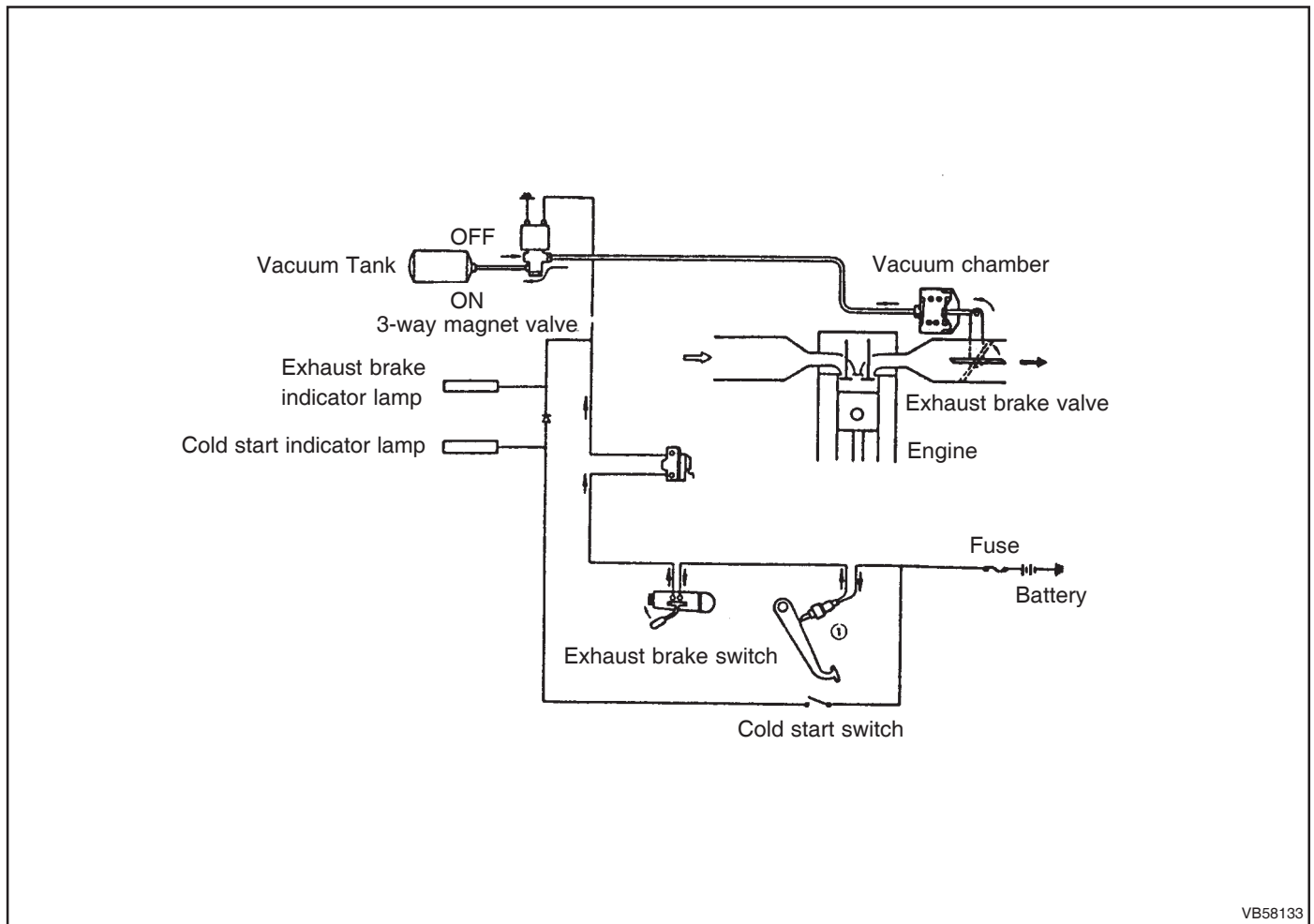

VB58133

The exhaust brake system, functioning as an auxiliary brake for the foot brake, consists of the butterfly valve type exhaust brake unit and the intake silencer that minimizes intake noise occurring when the exhaust brake is activated.

When the exhaust brake switch is turned ON, the 3-way magnet valve actuates causing air pressure in the air tank to be delivered to the control cylinder of the exhaust brake unit. This closes the exhaust brake valve, thus activating the exhaust brake. At the same time, the air pressure is delivered to the control cylinder of the intake silencer, which closes the intake silencer valve. Depression of either clutch pedal or accelerator pedal, or shifting into natural turns OFF the electric circuit temporarily, deactivating the exhaust brake system.

The pressure inside the exhaust pipe building up when the exhaust pipe is closed is applied to the piston as a counteracting force during the exhaust stroke, which offers the braking force.

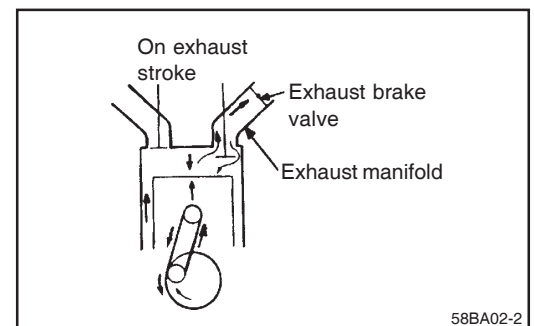

58BA02-2

EXHAUST BRAKE

Exhaust brake valve

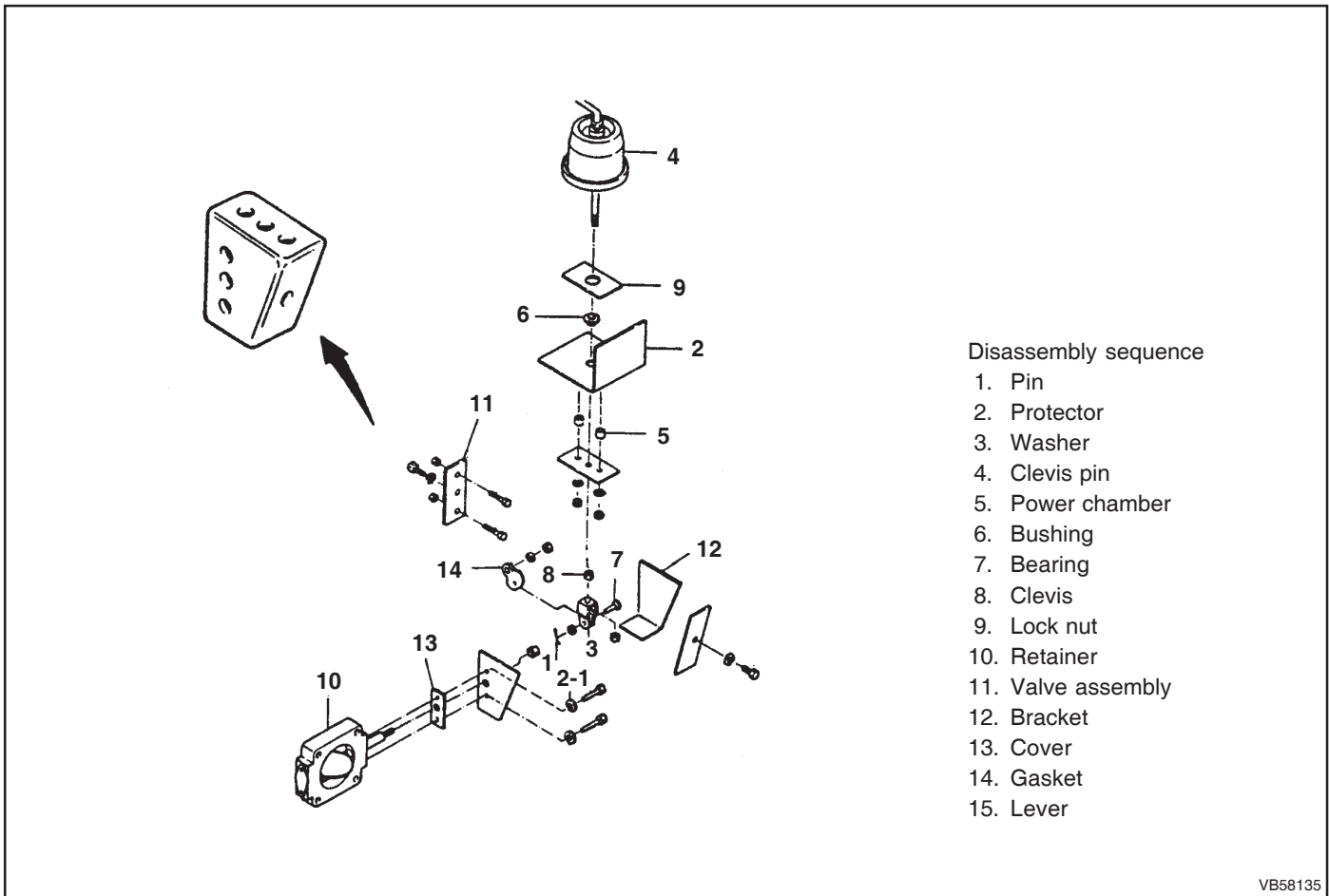

VB58135

Inspection

Airtightness check

- 1) Apply vacuum of -500mmHg or more to power chamber and check wheather the vacuum gauge indicates nominal vlue after 15 seconds

Nominal value	-475mmHg or more
---------------	------------------

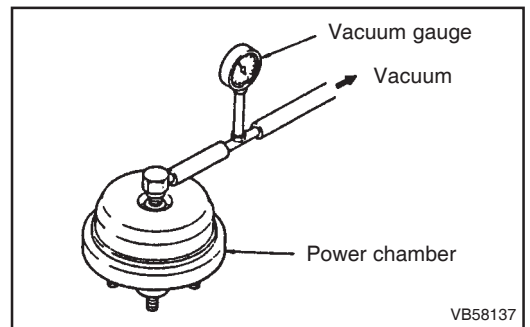

VB58137

Assembly procedure

- 1) Adjustment of fully opened butterfly valve.
Turn the adjusting bolt until the adjusting bolt head reaches the same height as of lever and tighten the bolt with lock nut.

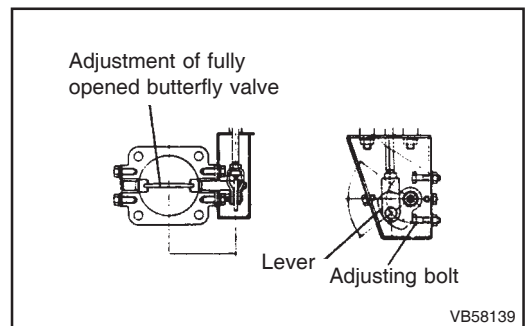

VB58139

2) Adjustment of clevis length

Depress the power chamber to the adjusting bolt (of fully opened position) contacts with lever then adjust the clevis position as shown is illustration beside and tighten with lock nut.

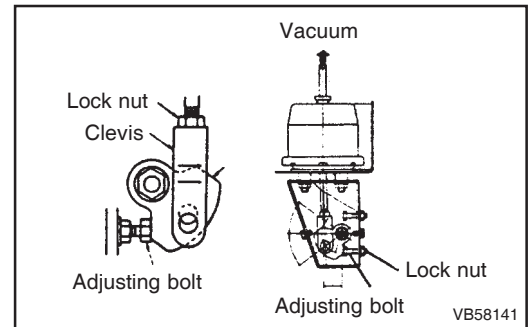

3) Adjustment of closed butterfly valve

While applying -650mmHg of vacuum pressure, turn the adjusting bolt and make sure that the clearance between butterfly valve and body is to 0.4-0.6 mm then tight the lock nut.

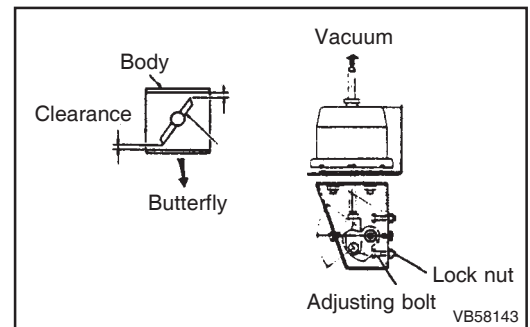

Reassembly

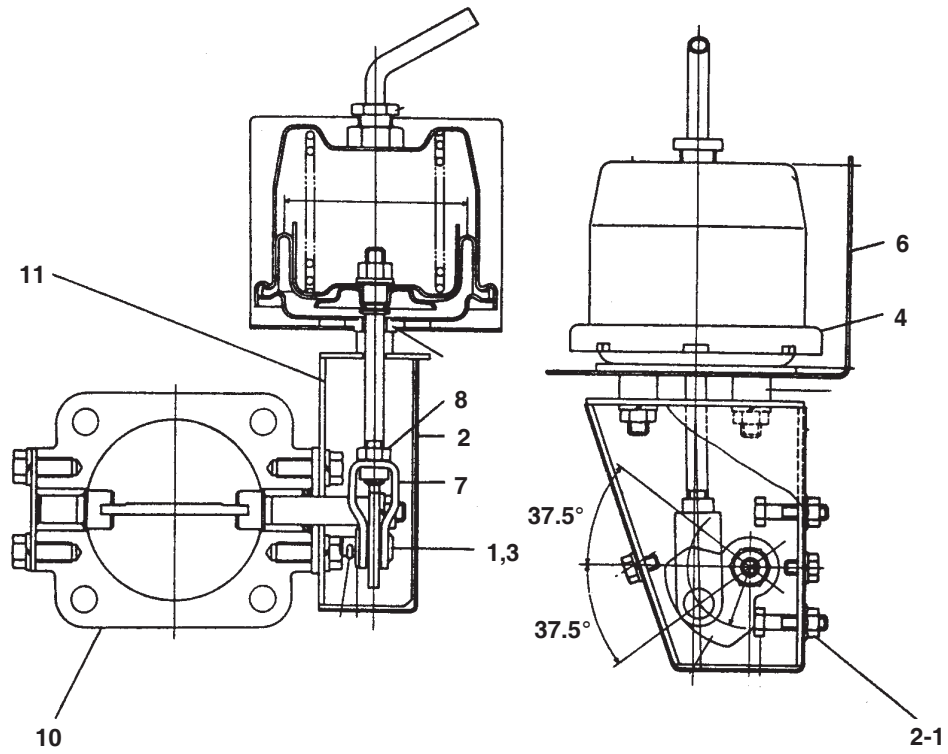

Reassembly sequence

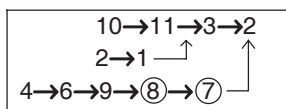

TROUBLESHOOTING

Symptom	Probable cause	Remedy
Poor braking action	Loosen of brake fluid	Check for brake fluid leaks, correct and add brake fluid
	Air in system	Bleed the system
	Leaks in brake fluid line	Correct the leaks and add brake fluid
	Leaky brake master cylinder and wheel cylinder	Correct or replace the assembly
	Excessive brake shoe clearance	Adjust shoe clearance. If brake lining wears exceeding the limit, replace the lining.
	Worn brake lining	Replace brake lining
	Defective master cylinder, wheel cylinder, and hydromaster	Check the parts and replace as necessary
	Water or grease between the brake drum and brake lining	Clean, or replace brake lining
	Burnt brake lining	Replace brake lining
	Poorly lubricated brake booster power cylinder or air leaking due to damaged rubber packing	Replace defective parts and lubricate power cylinder
Excessive pedal travel	Excessive brake shoe clearance	Adjust shoe clearance. If brake lining wears exceeding the limit, replace the lining.
	Loss of brake fluid	Check for brake fluid leaks, correct and add brake fluid
	Leaks in brake fluid line	Correct the leaks and add brake fluid
	Leaky brake booster	Check the parts and replace as necessary
	Defective brake master cylinder piston cup	Replace piston complete
	Air in system	Bleed the system
	Excessive brake pedal play	Check and replace parts as necessary
Vehicle pulls to one side when braking	Improper brake shoe clearance or brake lining contact	Adjust shoe clearance. Replace linings.
	Grease on linings or drum internal surfaces	Remove contaminants or replace linings
	Brake drum runout or left loose	Correct runout. Tighten drum to specification.

Symptom	Probable cause	Remedy
Vehicle pulls to one side when braking	Tires not uniformly inflated	Inflate correctly
	Mismatched lining materials	Use same linings
	Brake shoe return spring lost tension or broken	Replace return spring
	Chassis spring U-bolt left loose	Tighten U-bolt nut to specification
	Distorted backing plate	Replace backing plate
	Defective wheel cylinder	Disassemble wheel cylinder, check body, piston, and cup, and replace parts as necessary
All brakes drag	Small brake shoe clearance	Adjust shoe clearance on four wheels
	No play in brake pedal; poor brake pedal return action	Adjust play in brake pedal. Lubricate collar and bushing internal surfaces for smooth brake pedal action.
	Weak or broken brake pedal and brake master cylinder return springs	Check and replace as necessary
	Plugged brake master cylinder return port	Disassemble and clean
	Brake master cylinder piston cup deformed	Replace piston complete
	Defective brake booster relay valve	Replace binding relay valve piston
	Defective brake booster power piston	Lubricate rubber packing as necessary
One brake drags	Small brake shoe clearance	Adjust shoe clearance
	Weak or broken brake shoe return spring	Replace
	Restricted oil pipe	Clean or replace
	Brake shoe assembly installed improperly	Correct
	Defective wheel cylinder	Check piston and piston cup and replace as necessary
Brakes squeak	Brake drum dragging	Check and correct by referring to above
	Brake linings are worn causing the drum to come into contact with rivet heads	Replace linings
	Hardened lining surfaces	Replace linings
	Rough or worn brake drum internal surfaces	Correct surfaces or replace
	Brake drum becoming loose	Tighten to specification
	Brake shoe not in tight contact with lining	Replace linings
	Brake shoe assembly installed improperly	Poor braking action or sticking brake pedal

Symptom		Probable cause	Remedy
Poor braking action or sticking brake pedal		Complete vacuum in not created	Check connections and pipings and replace as necessary. Or check vacuum pump.
		Vacuum is not held properly	Check connections and pipings and replace as necessary. Or, check the vacuum tank check valve, brake booster poppet valves (vacuum valve, air valve), power piston packing, and diaphragm and replace as necessary
		Defective brake booster relay valve	Check the brake booster fluid line and clean and replace as necessary
Poor braking action		Brake booster not airtight	Check poppet valve (air valve), power piston packing, and diaphragm for airtightness and replace as necessary
Pedal springs back		Brake fluid on the wheel cylinder side flows back to the master cylinder side at the hydraulic cylinder of brake booster	Replace hydraulic piston assembly or cup packing
Starting the engine produces braking		Defective brake booster relay valve	Check for relay valve piston's return motion and valve seals and replace as necessary
Exhaust brake	Exhaust brake ineffective	Abnormal air pressure	Check for air compressor performance and piping and correct as required Check and repair clutch switch, microswitch, and exhaust brake harness
		Faulty electrical circuit	Replace
		Air piping crushed	Replace
		3-way magnet valve inoperative	Clean
		Exhaust brake valve inoperative	Replace
		Exhaust brake valve shaft sticking	Disassemble control cylinder and replace defective parts
	Control cylinder inoperative	Replace	
	Exhaust brake cannot be released	3-way magnet valve inoperative	Clean
		Exhaust brake valve inoperative	Replace
		Exhaust brake valve shaft sticking	Check and repair clutch switch, microswitch, and exhaust brake harness
Faulty electrical circuit		Replace	

(1) Wheel brakes

Symptom		Probable cause	Remedy
Poor braking action	Air leaks when brake pedal is depressed	Loosen connectors	Tighten connectors
		Leaky primary and secondary valves of dual brake valve	Disassemble dual brake valve to remove foreign matter or replace inlet valve
		Damaged dual brake valve O-ring	Disassemble dual brake valve and replace O-ring
Air leaks when brake pedal is released	Loosen connectors	Tighten connectors	
		Leaky primary and secondary valves of dual brake valve	Disassemble dual brake valve to remove foreign matter or replace inlet valve
Low air pressure	Air leak	Check air line and correct air leaks	
	Air pressure governor improperly adjusted	Adjust air pressure governor	
	Air compressor malfunctioning	Overhaul air compressor	
No air leaks	Brake booster power cylinder poorly lubricated or rubber parking damaged	Apply grease to cylinder shell inner surface and rubber packing. Replace damaged rubber parking	
	Poor sealing by the brake booster hydraulic piston valve seal	Replace the valve seal	
	Damage or wrong cup packing in brake booster hydraulic piston. Or foreign matter deposited on packing.	Replace and reinstall correctly the cup packings	
	Excessive brake shoe clearance	Adjust shoe clearance. Replace brake lining if it has worn to limit.	
	Oil or grease on brake lining	Wash deposits off the surface or replace brake lining	
	Hardended lining surface	Machine brake lining surface or replace lining	
	Brake fluid leak from fluid circuit or loss of brake fluid	Correct the leaks and bleed the system. Or add brake fluid up to "H" level.	
	Air in fluid line	Bleed the line	
	Worn wheel cylinder cup resulting in brake fluid leak	Replace cup	

Symptom		Probable cause	Remedy
Brake drum overheats	The brake shoes are not moving away from the brake drum when the brake pedal is released (brake dragging)	Improper return motion of the primary or secondary valve of the dual brake valve, or exhaust port being plugged with foreign matter	Disassemble, check, and clean dual brake valve and correct problem or replace
		Brake booster exhaust port plugged with foreign mater	Disassemble, check, and clean brake booster and correct problem or replace
		Bent brake booster push rod	Replace push rod
		Brake booster power cylinder rubber packing poorly lubricated	Apply grease to rubber packing
		Small brake shoe clearance	Adjust shoe clearance
		Weak or broken brake shoe return spring	Replace return spring
		Poor return motion of wheel cylinder piston and cup	Replace piston and cup
		Brake fluid not returning due to blocked brake pipe and joint	Remove and flush with brake fluid, or replace
Brakes are noisy when pedal is depressed		Brake lining worn to allow rivet head to be exposed	Replace brake lining
		Hardened brake lining	Replace brake lining
		Unevenly worn brake drum inner surface	Machine or replace drum
		Brake shoe not in tight contact with brake lining	Replace brake lining
		Brake drum left loose	Retighten
Vehicle pulls to one side when brake pedal is depressed		Improper brake shoe clearance or brake lining in poor contact	Adjust shoe clearance. Correct poor contact or reline brake lining
		Oil or grease on brake lining and brake drum inner surface	Completely remove deposits or reline brake lining
		Brake drum runout, or left loose	Correct runout. Retighten
		Uneven right and left inflation pressures	Adjust to specified inflation pressure
		Different brake lining materials used	Reline brake lining or pad of the same material
		Weak or broken brake shoe return spring	Replace return spring
		Chassis spring U-bolt left loose	Retighten
		Deformed backing plate	Replace backing plate
		Wheel cylinder piston malfunctioning	Disassemble when cylinder, check body, piston, and cup, and replace any defective part
Abrupt braking action of wheel brakes		Small brake shoe clearance	Adjust shoe clearance
		Large brake shoe clearance	Adjust shoe clearance
① indicator lamp lights up		Air in brake system	Bleed system
		Brake fluid leak from fluid circuit	Correct leaks

(2) Air dryer

Symptom		Probable cause	Remedy
Air dryer	Air tank drain cock drains	Desiccant becoming ineffective	Replace desiccant, oil filter, and filter
	Exhaust port does not drain	Heater fails to operate and air dryer is frozen	Replace heater if defective. Replace thermostat if defective
	Air dryer interior is frozen	Valve inoperative due to foreign matter trapped	Disassemble and check valve and replace valve complete as necessary
		An open-circuited heater aggravating heat insulating effect	Check heater for continuity with a multimeter and replace heater if there is an open circuit
		Heater inoperative due to defective thermostat	Use following procedure to check thermostat and replace if found defective <ul style="list-style-type: none"> o Leave thermostat under environment 0°C or below and check for continuity using a multimeter. o heat thermostat to make sure that it turns OFF at temperature between 0°C and 20°C.
		Snow being packed on air dryer, lowering temperature to an abnormal low	Remove snow and ice with care not to damage air dryer and heater wires
		Heater inoperative due to heater and thermostat wires left disconnected	Connect heater and thermostat wires properly
		Air leaks from exhaust port	Valve fails to seat properly due to foreign matter
	Engine oil is discharged from exhaust port	Oil working up in air compressor	Replace piston rings an cylinder liner

ANTI-LOCK BRAKE SYSTEM

GENERAL	BRb - 2
SERVICE PROCEDURE	BRb - 8
TROUBLESHOOTING	BRb-12

GENERAL

A.B.S

1. A.B.S Function

When vehicle is braked while driving, or braked suddenly, or road is slippery due to rain or snow, skid happens easily, When skid happens, braking force is reduced and stopping distance is lengthened. Or it may cause an accident because the vehicle slips to the wrong direction and handle steering is worsened. So ABS is a safety seeking system that prevents wheel stuck or slips to maintain the vehicle direction stability and ensures the steering control and achieves optimum stopping distance.

2. Structure of A.B.S

- 4S/3M (4 Wheel speed sensors, 3 Modulator valves) : AOH BRAKE
- 4S/4M (4 Wheel speed sensors, 4 Modulator valves) : FULL AIR BRAKE

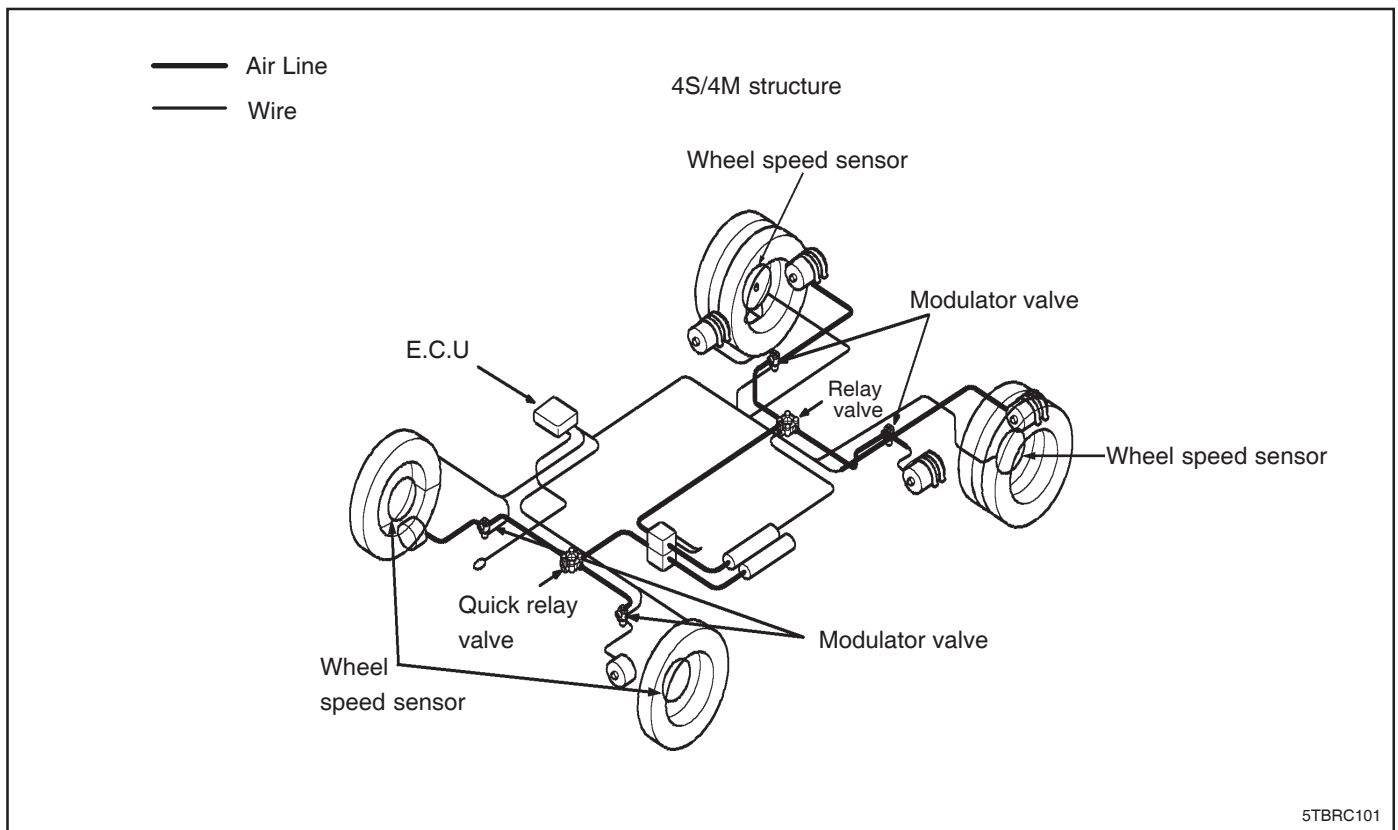

4S/4M is a basic structure diagram in this book.

3. A.B.S Warning lamp

ABS warning lamp operates as follows.

Ignition Switch ON. 	Normal operation	A.B.S warning light turns off after flashing instantly.	System is in normal operation
	After repairs of A.B.S system	A.B.S warning light remains on when ignition switch in the ON position	Lamp turns off if the vehicle drives faster than 7 km/h and system is in normal operation.
	Defective.	A.B.S warning light remains on when ignition switch in the ON position	Warning light remains on when the vehicle drives faster than 7 km/h. ABS system is defective.

SPBR-005

If the ECU senses a fault when driving a vehicle, ABS warning light turns on.

4. ABS modulator valve

ABS modulator valve controls air pressure of corresponding brake. 2 modulator valves of rear axle wheel are installed at the right side frame of rearward, and 2 A.B.S modulator valves are installed at front axle frame. And relay valve is used to deliver air pressure to the A.B.S modulator valve.

* Easy detection by sound
 We can check ABS operation by the air breathing sound coming from ABS modulator valves.

1. Brake pedal is depressed
2. Turn on the Ignition switch
3. Wait for ABS warning light turns on
4. Listen to the valve cycle one by one at the diagonal direction.

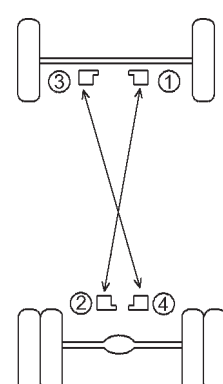

5TBRC-102

5. ABS sensor

ABS system consists of pulse wheel installed at the wheel hub, and sensor at the opposite direction of the pulse wheel. Sensor feedback the information on the wheel speed to the ECU continuously. The shape of shafts sets sensor position.

- Steering shaft sensor is installed at the steering knuckle.
- Drive shaft sensor is installed at the shaft-housing block.

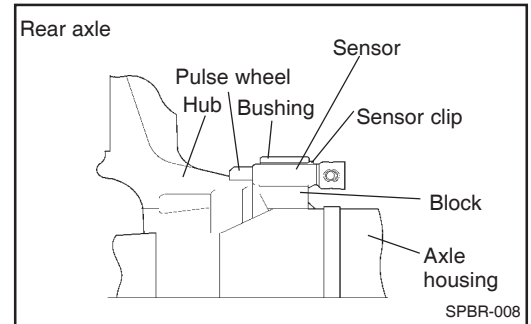
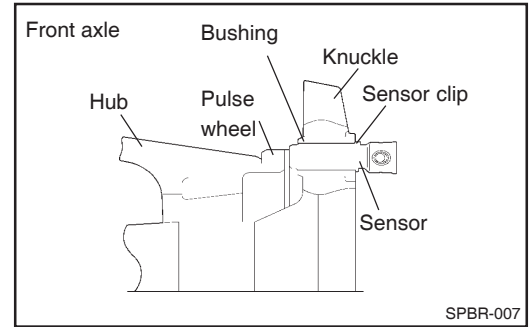

6. Structure of E.C.U system

ECU corresponds to the brain of ABS system. This system receives the information from sensors and remits the signals to ABS modulator valve.

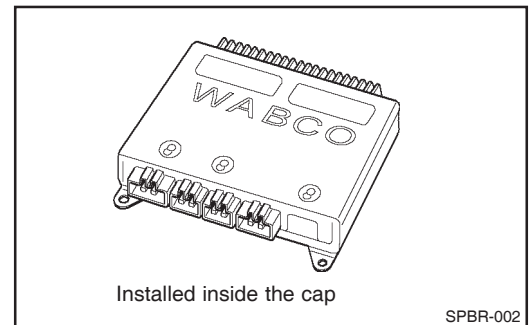

Installed inside the cap

ECU version is displayed on the part number identification tag.

4S/4M (F/AIR) : 446 004 411 0

4S/3M(AOH) : 446 004 413 0

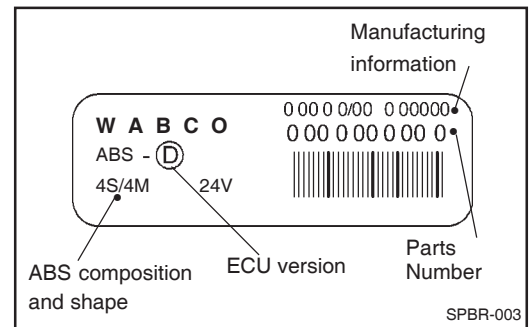

WHEEL SPEED SENSOR

Pulse wheels (a) are installed at the wheel hubs facing the ends of sensors (b). Sensor is fixed with sensor clip (c).

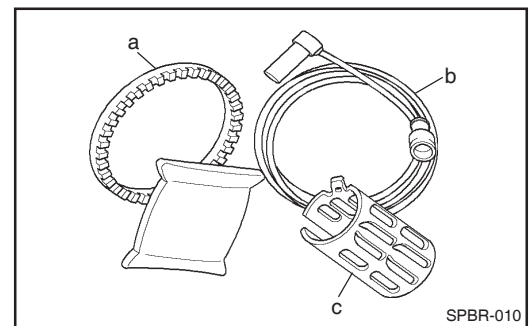

A.B.S modulator valve

ABS modulator valve controls the air pressure of the corresponding brake in ABS operation.

Generally speaking, modulator valve is placed on the cross member or frame side rail near brake chamber.

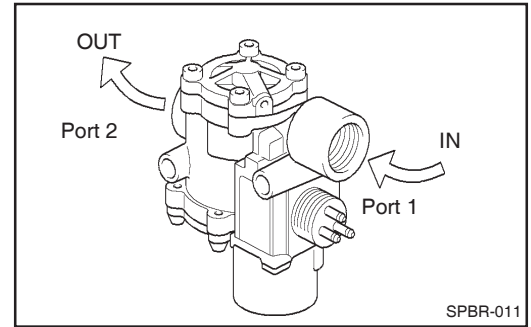

ASR operation principle

1. This system reduces the slips of driving wheel when driving on a slippery road, and improves the towing capability. If one driving wheel starts slip, ASR applies air pressure to brake the wheel and then engine torque is delivered to the better towing wheel.

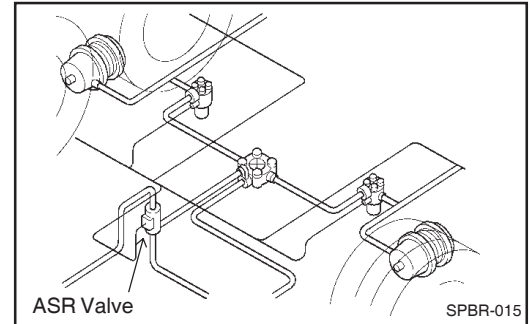

2. Since ASR operates by itself, driver doesn't have to select on/off mode. When driving wheel slips in acceleration, ASR indication light turns on and it stops when slip stops.

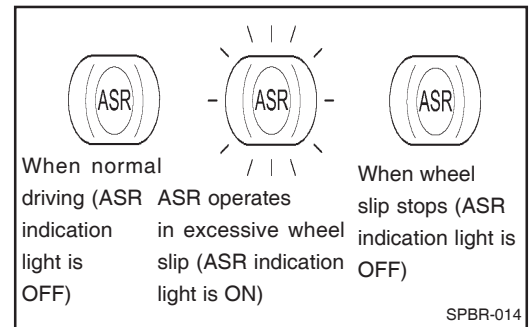

3. When ASR is installed, ASR is displayed on the meter set as "ASR".

ASR OPERATION

1. Differential Brake Control

If the slip rate of one drive wheel exceeds specified slip rate, ECU controls ASR valve and ABS modulator valve to brake the slipping wheel. If the slip rate lies within the specification, brake is released.

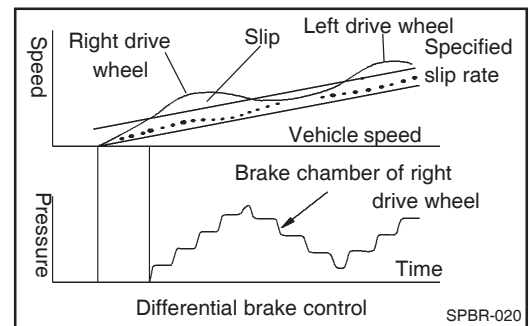

DIAGRAM

Air over hydraulic brake

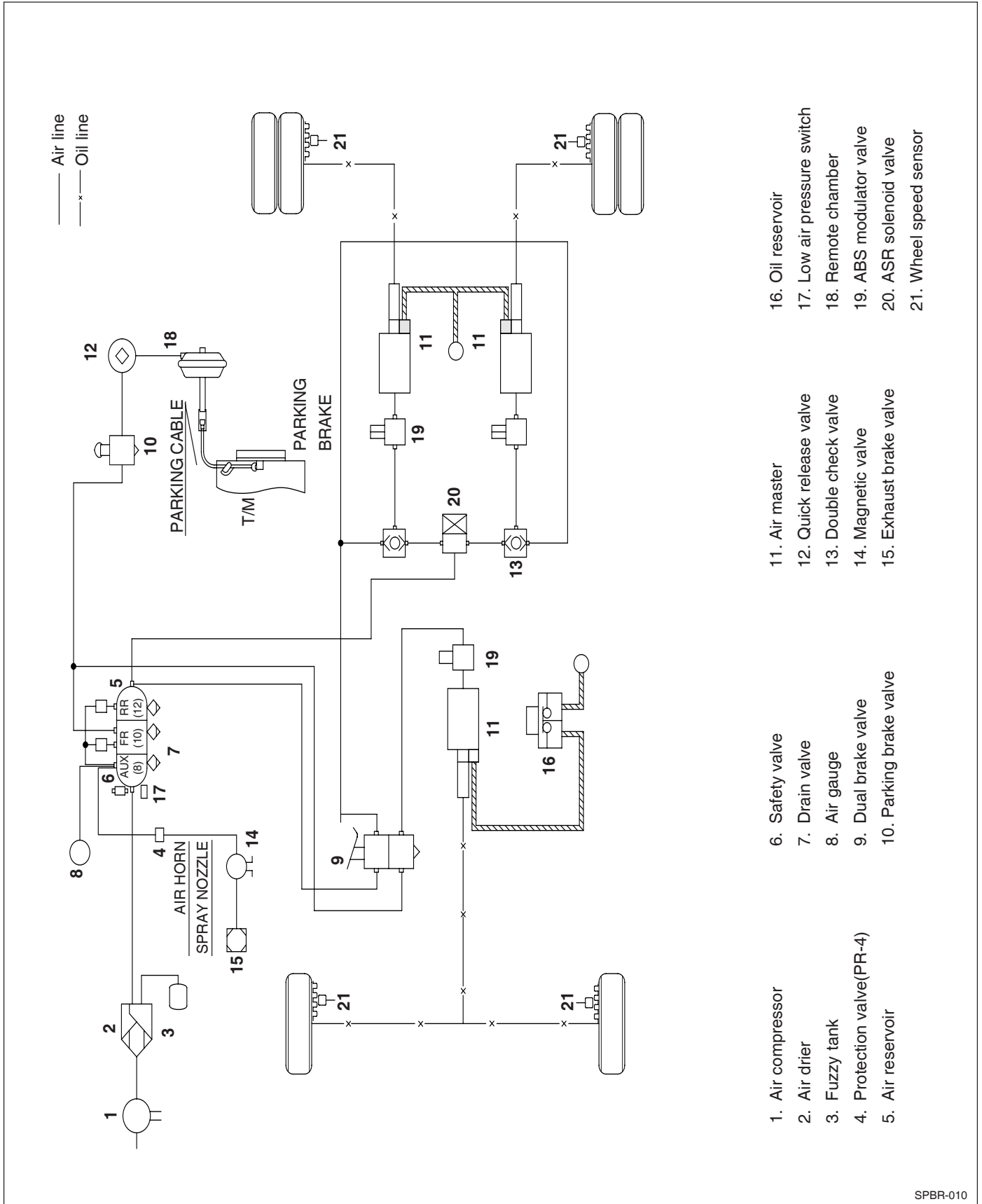

Full air brake

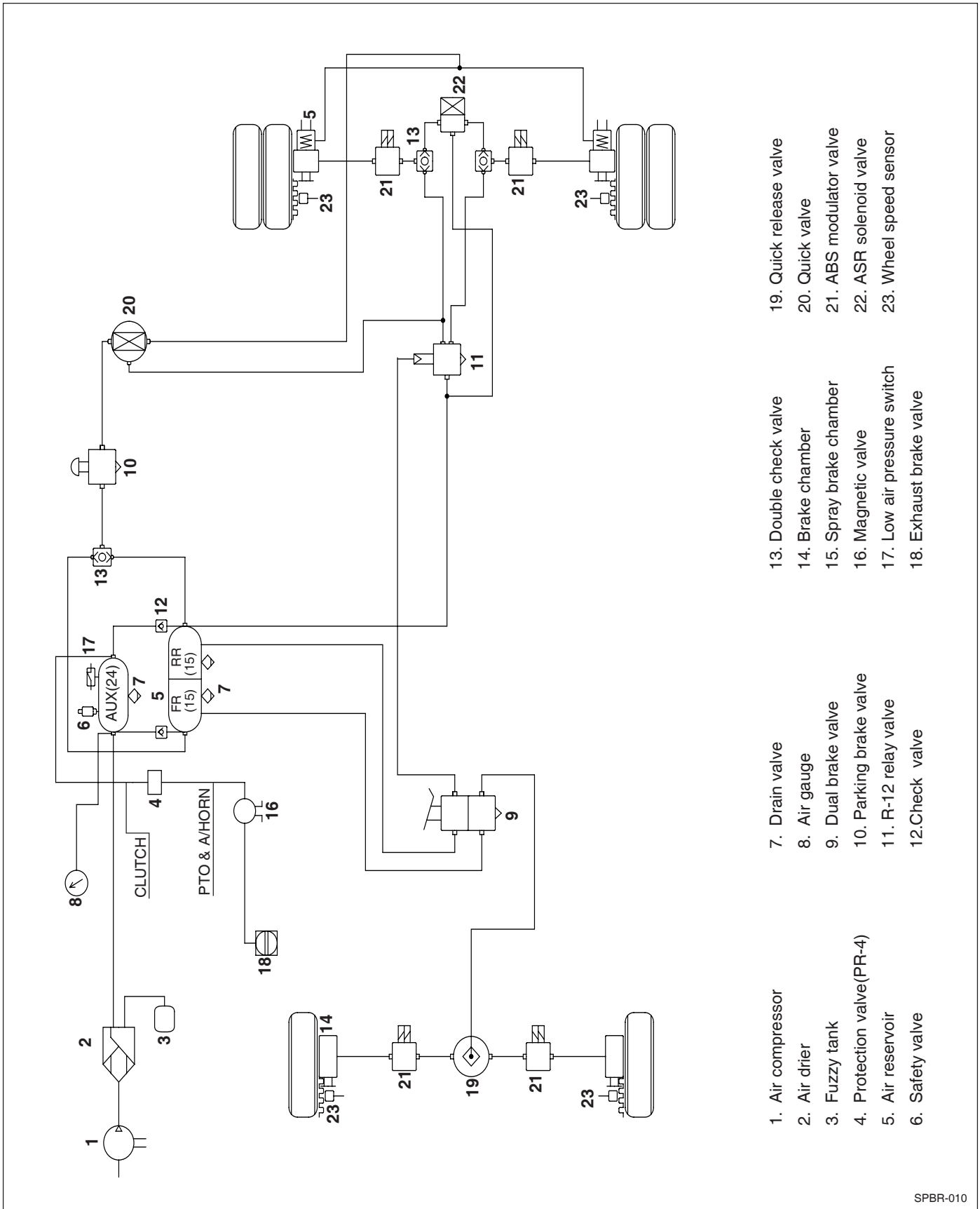

SERVICE PROCEDURE

WHEEL SPEED SENSOR

1. Removal of wheel speed sensor-Front Axle
 - Block both the rear tires and apply the parking brake firmly.
 - Lift up the tire and put a safety support beneath the axle if needed.
 - Remove the wire clamp, which holds the sensor cable.
 - Remove the sensor cable from chassis wires.
 - Remove the sensor from sensor holder and rotate to remove if needed. Do not pull the cable
2. Installation of wheel speed sensor – Front axle
 - Connect the sensor cable to chassis wires.
 - Install the wire clamp to fix the sensor cable.
 - Apply the lubricant recommended by WABCO on the sensor spring clip and sensors.
 - Install the clip onto the sensor spring. Check the spring clip tap to face inside of the vehicle.
 - Push to insert sensor spring clip to bushing of the steering knuckle until the clip stops.

[Caution]

 - **Push by hands without using the tools.**
3. Push the sensor fully inside the sensor spring clip until it touches pulse wheel.
4. Remove the block and supports.

Removal of the wheel speed sensor – Rear axle

1. Block the tires so that the vehicle won't move
2. Lift up the rear tire and put a safety support beneath the axle
3. Release the parking brake, and rotate the slack adjuster to lengthen the lining clearance.
4. Remove wheel and tire assembly from the shaft.
5. Remove the brake drum and hub.
6. Remove sensor from the mounting block of the axle housing. Rotate it to remove if needed. Do not pull the cable.
7. Remove the sensor spring clip from mounting block.
8. Remove sensor cable clamp.
9. Remove the sensor cable from chassis wire.

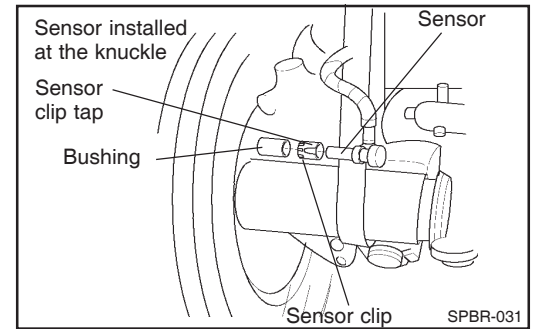

Installation of wheel speed sensor - Rear Axle

1. Apply the lubricant recommended by WABCO on the sensor spring clip and sensor.
2. Install sensor spring clip. Check whether spring tap clip faces inside vehicle.
3. Push to insert sensor spring clip to sensor holder until the clip stops.
4. Push the sensor fully inside the sensor spring clip until it touches pulse wheel.

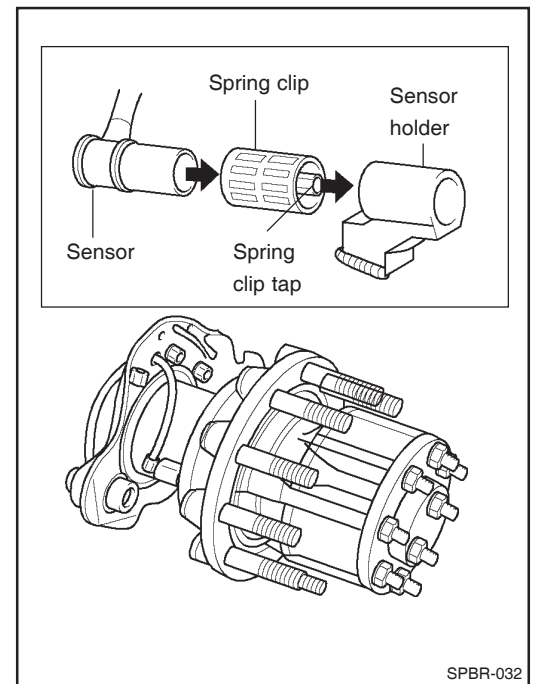

5. Be careful with the sensor cable not to interfere with brake shoe.
6. Note that cable shouldn't be tightened too much nor cut off, and enough space should be assured for the moving of suspension system.
7. Connect sensor cable to chassis wire.
8. Install sensor cable clamp.
9. Install wheel hub and brake drum assembly.

CAUTION

- **Be careful not to shock to the wheel speed sensor.**

10. Adjust the sensor using flange hole of axle if needed with the rod of $\varnothing 5$. When the adjustment is not enough, readjust it after removing drum assembly.

A.B.S MODULATOR VALVE

Removal of A.B.S modulator valve

1. Set the ignition switch at "OFF" position and apply the parking brake firmly
2. Block both front and rear tires so that the vehicle do not move.
3. Lift up the tires and put a safety support beneath the axle if needed.
4. Remove the wire connector from ABS valve
5. Remove the air-line from ABS valve port 1 (inlet) and port 2 (outlet).
6. Remove 2 mounting screws and nuts.
7. Remove ABS valve.

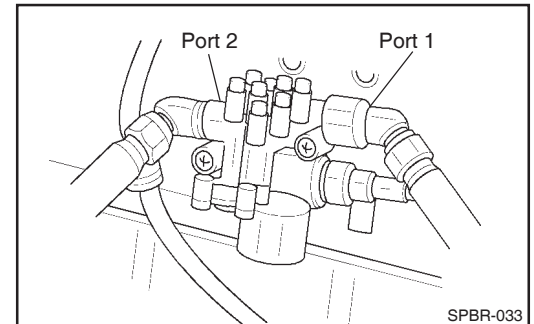

Installation of ABS modulator valve

1. Install ABS valve with 2 mounting screws and nuts. Tighten the screw with the specified torque.
2. Connect the brake chamber line to ABS port 2. Connect the air supply to ABS valve port 1.
3. Connect the wire connector to ABS valve and tighten it with bare hands.
4. Remove the block and safety support.
5. Check the installation state.

Installation check

1. Apply the brake and listen to the air outlet sound from ABS modulator valve.
2. Check the electrical cable connection, when something is wrong with ABS modulator valve cycle after key switch on.
3. Check whether ABS warning light works properly while driving the vehicle.

ASR VALVE

Working principle of ASR valve

1. Turn the key switch "off:" and apply the parking brake.
2. Block the front and rear tires so that the vehicle won't move anyway.
3. Lift up the vehicle and safety support beneath the shaft, if needed.
4. Reduce the air pressure by releasing air from the air pressure tank.
5. Remove the key switch from ASR valve.

6. Remove the air-line from the port 1 (inlet) and port 2 (outlet) of ASR valve.
7. Remove 2 mounting screws and nuts. Remove ASR valve.

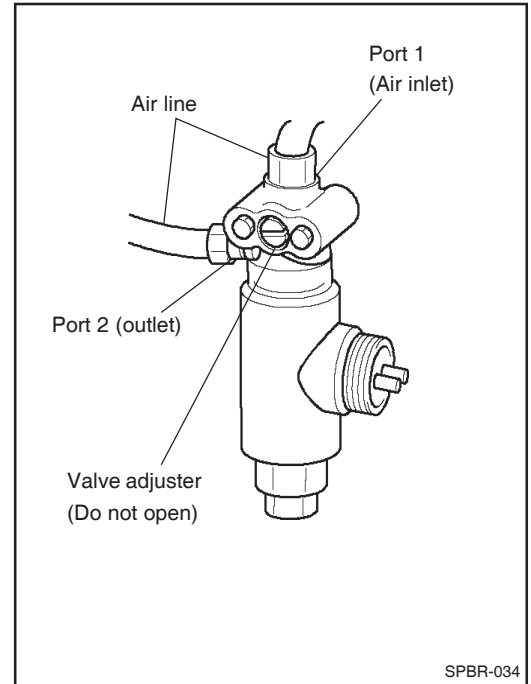

Installation of ASR valve

1. Install ASR valve with 2 mounting screws and nuts and tighten the screws with the specified torques.
2. Connect the air inlet line and air outlet line to port 1 and port 2 respectively.
3. Connect the wire connector to ASR valve and tighten with the bare hand.
4. Remove the block and safety support.
5. Check the installation state.

Installation check(Check for diagnostic device)

1. Start the engine.
2. Fill the air tank fully and park the car.
3. Press the brake pedal.
4. Operate and check the ASR valve.
5. Listen to the exhaust sound of ASR valve.
6. Release the brake pedal.
7. Remove the diagnostic device.
8. Check whether ABS warning lamp turns off while driving.

FAULT DIAGNOSIS AND TROUBLESHOOTING

1. Diagnosis

- Blink code diagnostic**
 Connect the connector under the instrument panel to the blink code switch. Diagnose any fault by operating the switch button as specified.
- Scan tool diagnostic**
 Diagnose as the operation manual by connecting connector under the instrument panel to the connector of the diagnostic tool.
- When no tool is available.**
 Connect the 2 wires to the connector as shown in the figure. Then you can diagnose by the blink code.

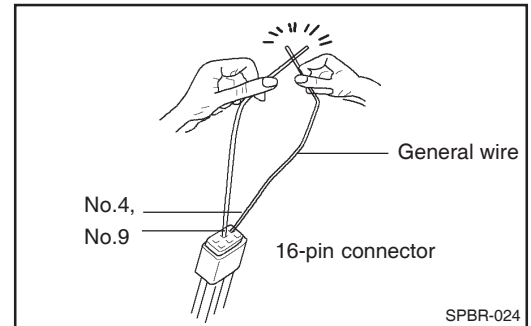
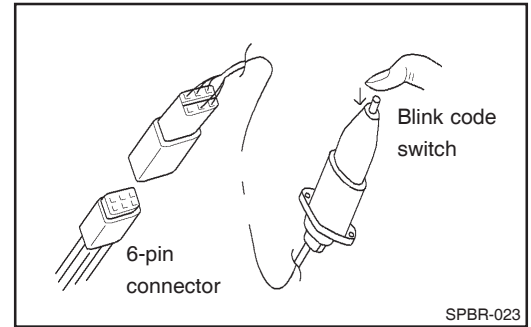

* KET TYPE

	1 Vehicle Speed	2 CAN(L) SAE J 1939	3 LINK(-),B SAE J 1708/1587	4 ABS CHECK	5 CAN - L (Low speed)	6 L-LINE ISO-9141	7 K/ENTRY CODE SAVING	8	<input type="checkbox"/> : RESERVED
	9 GND	10 CAN(H) SAE J 1939	11 LINK(+),A SAE J 1708/1587	12	13 CAN-H (Low speed)	14 K-LINE ISO-9141	15	16 BATT (12V,24V)	

5TBE-101

2. Operation of blink code

Press the blink code switch for a second and release it for the diagnosis.

One of the Following state can be the case in blink code diagnostic.

Symptom	Cause	Troubleshooting
ABS warning lamp doesn't turn on when the engine starts.	Bulb is not tightened enough or blown. Is the bulb blown?	Is the bulb blown? Is the bulb disconnected?
	Improper battery voltage (it must be within 22 and 32v)	Check ECU electrical wire of battery connector. Measure the voltage.
Blink code diagnostic failure (ABS warning lamp is on after the operation of blink code diagnostic)	Improper switch operation time Diagnosis = press it for a second Fault deletion = press it for 3 seconds.	Press the switch as specified.
	Wire connection is wrong.	Check the wire connection
Warning lamp doesn't blink for 8 times quickly after pressing the blink code switch for a minimum 3 seconds.	Fault still remains.	Find out and repair the fault.

3. Diagnostic procedures

Description	Procedure	Warning lamp blinking	Troubleshooting
Diagnosis	<ul style="list-style-type: none"> Stage 1 Turn the ignition key on	1. Normal if warning lamp turns on and turns off after a while. 2. When warning lamp does not turn on, wire has fault or fuse is blown. 3. If the warning lamp is on continuously, one of the following is the case, <ul style="list-style-type: none"> a. Fault b. Wheel speed sensor fault before engine off. c. Vehicle is not driven after ECU troubleshooting. d. ECU connector is disconnected. 	Normal (no troubleshooting is needed) Check wire or bulb. a. Proceed to stage 2 b. Proceed to stage 2. c. It's normal if the warning lamp turns off after driving the vehicle with 7 km/h (no troubleshooting is needed) d. Connect the connector
	<ul style="list-style-type: none"> Stage 2 Ground the terminal No 4 of diagnosis connector for 0.5 or 3.0 seconds or connect it to the terminal No 9.	Warning lamp blinks with 2-digit blink code.	Judge whether it is actual fault or memorized fault. In case of actual fault. - Repeat the one blink code cycle. In case of memorized fault - Blinking stops after showing the memorized faults. (Displayed only once)
	<ul style="list-style-type: none"> Stage 3 Check the blink code by counting the blinking	First unit blinking = blinking 1 to 8 times After 1.5 seconds 2nd unit blinking = blinking 1 to 6 times Repeat the first unit blinking after 4 seconds	Find out the faulty position reading the fault codes.
	<ul style="list-style-type: none"> Stage 4 Turn the ignition key off and shoot the fault.	In case of actual fault In case of memorized fault	Shoot the trouble and Repeat stage 1, 2 and 3 until it shows the normal code (1-1) Record the trouble for later use. (The last fault is displayed first code)
	Fault deletion	<ul style="list-style-type: none"> Stage 5 Turn the ignition key on and ground the terminal No 4 of diagnosis connector for 3.0 or 6.3 seconds or connect it to the terminal No 9.	System code is displayed after warning lamp blinking for 8 times. In case it won't blink 8 times. (System code is displayed)

ABS warning lamp mode and blink mode

1. Warning lamp operation

1) When system is normal

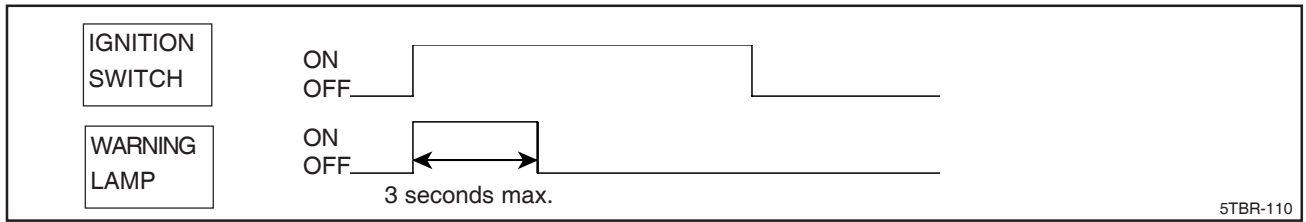

2) When system is abnormal (now)

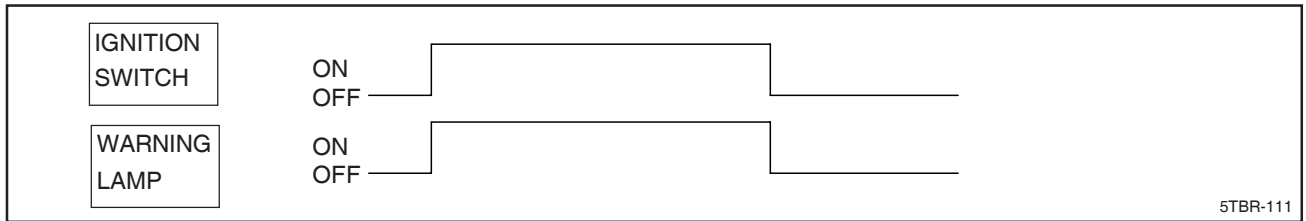

3) When sensor is abnormal in previous ignition on (normal now)

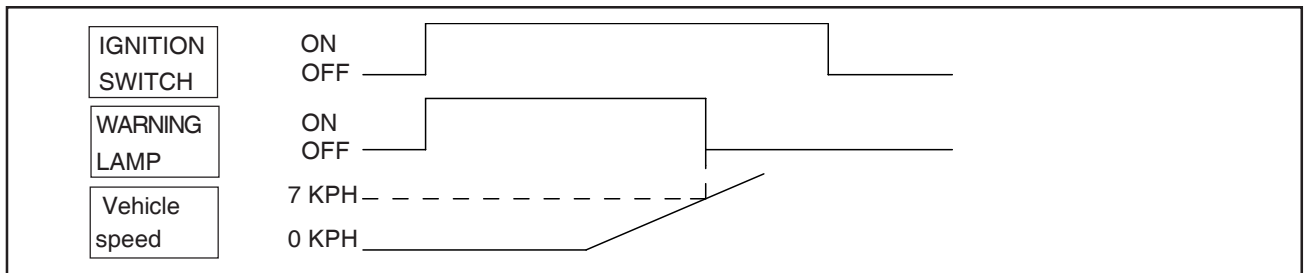

2. Fault diagnosis and fault code deletion using warning lamp

1) Diagnosis mode

a. Self-diagnostic mode start

Turn on the self-diagnostic switch on for 0.5 to 3.0 seconds

- If it is faulty now, it displays only 1 fault that happened lately.

※ Turning on the self-diagnostic switch is the same as connecting the terminal No 4 and terminal No 9 of the KET type diagnosis connector.

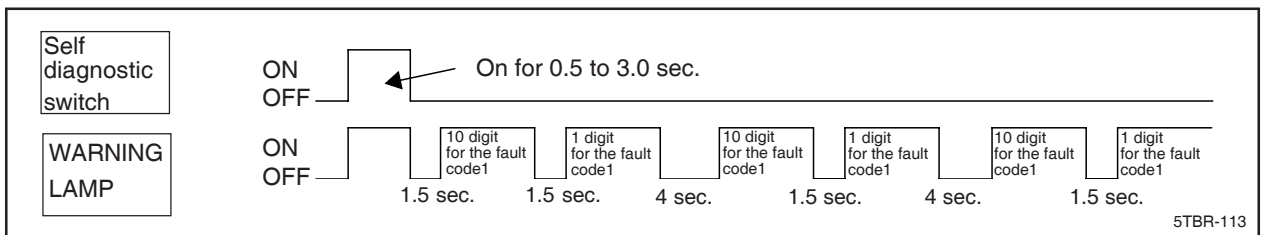

- If it is not faulty now, it displays the latest 4 fault codes in sequence from the latest one and the other fault codes more than 4 are displayed regardless of time sequence.

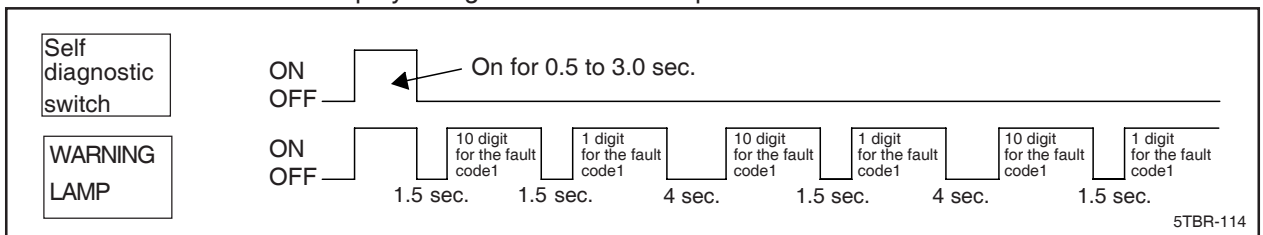

- Self-diagnostic mode terminates once ignition switch is turned off or vehicle speed is detected.

- b. Blink stops if the ECU terminal of warning lamp is grounded for 6.3 to 15.0 seconds during blink code output.

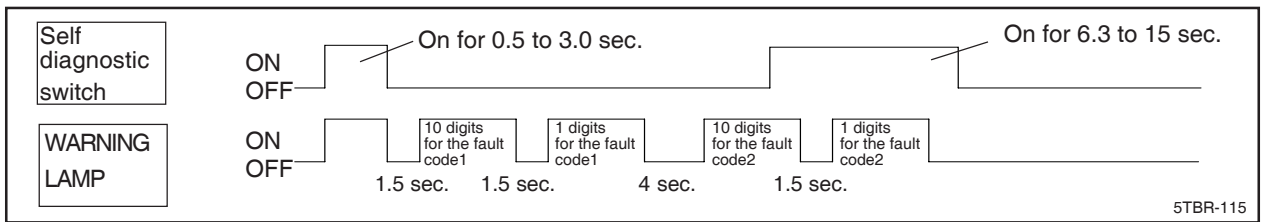

- c. If self-diagnostic switch is on more than 15 seconds in ignition on state, it judges as lamp fails and stores the mode into EEPROM.

2) System mode (fault code deletion)

- a. System mode start

Turn on the self-diagnostic switch for 3.0 to 6.3 seconds in ignition switch on state, and then system mode starts.

- When system is faulty now: system code is displayed continuously without fault code deletion.

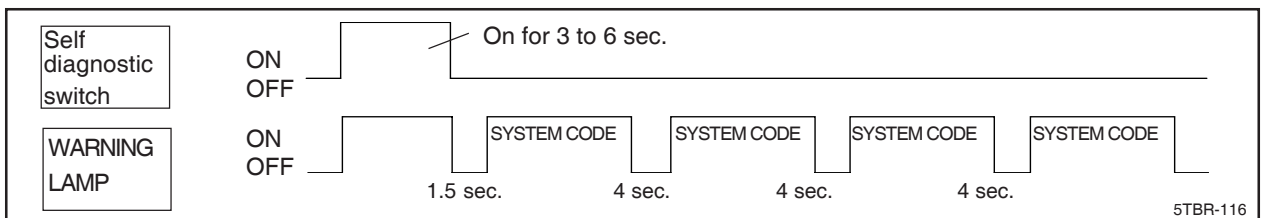

- When system is not faulty now: fault code is deleted and system code is displayed after lamp blinking 8 times in a short intervals.

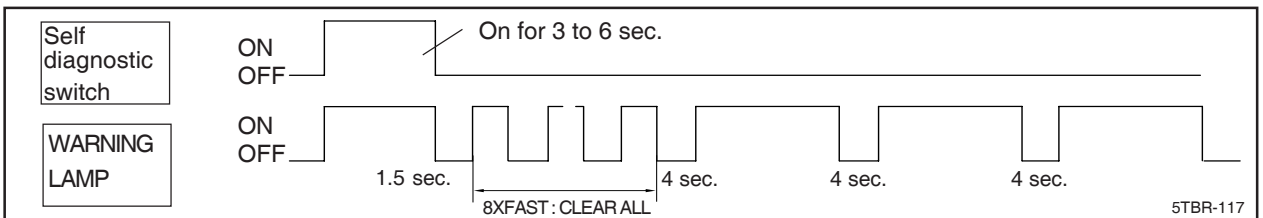

※ System code

- No 1: 6S/6M (6X2ATC), No 2: 4S/4M, No 3: 4S/3M (MAR/VAR FRONT), No 4: 6S/4M, No 5: 6S/6M (6X4ATC), No 6: 4S/3M (VAR REAR), No 7: 4S/2M(VAR BOTH)

- b. Function test (retarder reconfiguration)

After system code output for 3 times

- If the self-diagnostic switch is turned on 3 times with the interval of 0.5 and 3.0 seconds, retarder or exhaust relay is reset. In other words, retarder configuration is executed.

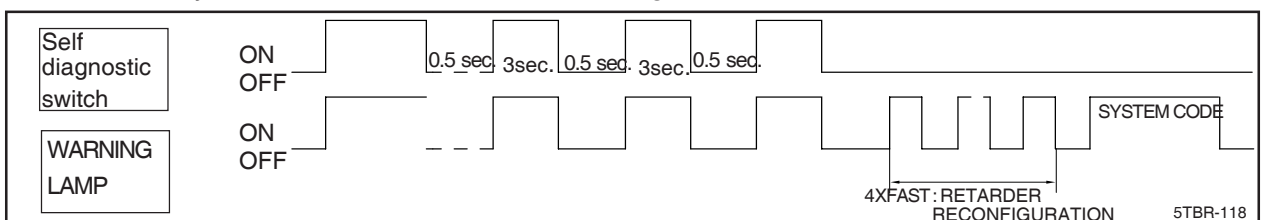

※ blink code timing

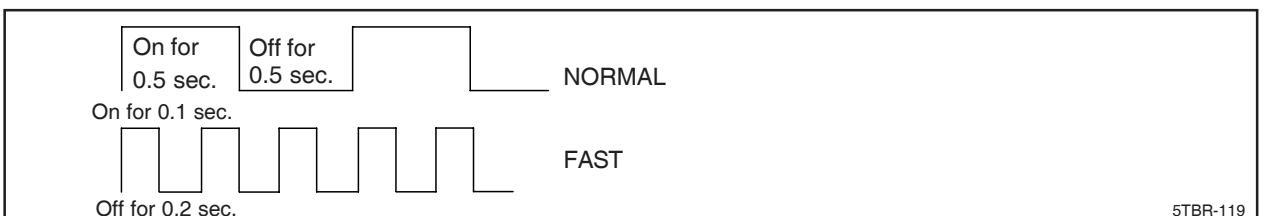

3. Specification of fault codes

1st digit (Fault type)	2nd digit (Fault location)
1=No faulty	1=No faulty
2=ABS Modulator 3=Too much air gap (Clearance between sensor and pulse wheel) 4=Short or disconnection of sensor harness 5=Sensor signal poor 6=Pulse ring defect	1=FRT STEER AXLE RH 2=FRT STEER AXLE LH 3=REAR DRIVE AXLE RH 4=REAR DRIVE AXLE LH
7=System faulty	1=Data communication poor 2=ASR valve faulty 3=Exhaust brake relay faulty 4=ABS warning lamp faulty 5=Poor set up ASR 6=Poor ASR engine control valve
8=ECU	1=Too low voltage 2=Too high voltage 3=Internal faulty 4=System faulty 4=Ground faulty

Fault location	Faulty Description	Fault Code	System reaction	Remedy type	Remarks
WSS FRT LH	Air gap	32	ABS : Doesn't active at specific wheel	1	
	Tire size	52		2	
	Short at power supply	42		3	
	Short at ground	42		4	
	Circuit cut	42	ATC : Doesn't active	5	
	Circuit short	42		6	
	Pulse ring	62		7	
	Slip	32		8	
	Circuit problem	52		9	
	Speed signal poor	32		10	
	Abnormal speed(Chattering)	52		11	
	Abnormal frequency	52		12	
WSS FRT RH	Air gap	31	ABS : Doesn't active at specific wheel	1	
	Tire size	51		2	
	Short at power supply	41		3	
	Short at ground	41		4	
	Circuit cut	41	ATC : Doesn't active	5	
	Circuit short	41		6	
	Pulse ring	61		7	
	Slip	31		8	
	Circuit problem	51		9	
	Speed signal poor	31		10	
	Abnormal speed(Chattering)	51		11	
	Abnormal frequency	51		12	
WSS REAR LH	Air gap	34	ABS : Doesn't active at specific wheel	1	
	Tire size	54		2	
	Short at power supply	44		3	
	Short at ground	44		4	
	Circuit cut	44	ATC : Doesn't active	5	
	Circuit short	44		6	
	Pulse ring	64		7	
	Slip	34		8	
	Circuit problem	54		9	
	Speed signal poor	34		10	
	Abnormal speed(Chattering)	54		11	
	Abnormal frequency	54		12	
WSS REAR RH	Air gap	36	ABS : Doesn't active at specific wheel	1	
	Tire size	56		2	
	Short at power supply	46		3	
	Short at ground	46		4	
	Circuit cut	46	ATC : Doesn't active	5	
	Circuit short	46		6	
	Pulse ring	66		7	
	Slip	36		8	
	Circuit problem	56		9	
	Speed signal poor	36		10	
	Abnormal speed(Chattering)	56		11	
	Abnormal frequency	56		12	

Fault location	Faulty Description	Fault Code	System reaction	Remedy type	Remarks
WSS 3RD LH	Air gap	35	ABS :	1	
	Tire size	55	Doesn't active at specific	2	
	Short at power supply	45	wheel	3	
	Short at ground	45		4	
	Circuit cut	45	ATC :	5	
	Circuit short	45	Doesn't active	6	
	Pulse ring	65		7	
	Slip	35		8	
	Circuit problem	55		9	
	Speed signal poor	35		10	
	Abnormal speed(Chattering)	55		11	
	Abnormal frequency	55		12	
WSS 3RD RH	Air gap	33	ABS :	1	
	Tire size	53	Doesn't active at specific	2	
	Short at power supply	43	wheel	3	
	Short at ground	43		4	
	Circuit cut	43	ATC :	5	
	Circuit short	43	Doesn't active	6	
	Pulse ring	63		7	
	Slip	33		8	
	Circuit problem	53		9	
	Speed signal poor	33		10	
	Abnormal speed(Chattering)	53		11	
	Abnormal frequency	53		12	
MODULATOR FRT LH	Inlet,outlet valve circuit cut	22	ABS :	13	
	Circuit cut	22	Doesn't active at specific	15	
	Short at ground	22	wheel	16	
	Short at power supply	22	Does'nt active at FRT RH, REAR LH(3RD LH),ATC	14	
MODULATOR FRT RH	Inlet,outlet valve circuit cut	21	ABS :	13	
	Circuit cut	21	Doesn't active at specific	15	
	Short at ground	21	wheel	16	
	Short at power supply	21	Does'nt active at FRT RH, REAR LH(3RD LH),ATC	14	
MODULATOR REAR LH	Inlet,outlet valve circuit cut	24	ABS :	13	
	Circuit cut	24	Doesn't active at specific	15	
	Short at ground	24	wheel	16	
	Short at power supply	24	Does'nt active at FRT RH, REAR LH(3RD LH),ATC	14	
MODULATOR REAR RH	Inlet,outlet valve circuit cut	23	ABS :	13	
	Circuit cut	23	Doesn't active at specific	15	
	Short at ground	23	wheel	16	
	Short at power supply	23	Does'nt active at FRT RH, REAR LH(3RD LH),ATC	14	
MODULATOR 3RD LH	Inlet,outlet valve circuit cut	26	ABS :	13	
	Circuit cut	26	Doesn't active at specific	15	
	Short at ground	26	wheel	16	
	Short at power supply	26	Does'nt active at FRT RH, REAR LH(3RD LH),ATC	14	

Fault location	Faulty Description	Fault Code	System reaction	Remedy type	Remarks
MODULATOR 3RD LH	Inlet,outlet valve circuit cut	25	ABS :	13	
	Circuit cut	25	Doesn't active at specific	15	
	Short at ground	25	wheel	16	
	Short at power supply	25	Does'nt active at FRT RH, REAR LH(3RD LH),ATC	14	
Retardar (DBR circuit)	Short at power supply	73	Doesn't active at DBR	17	
	Circuit cut	73		59	
	Short at ground	73		19	
Power	DIAGONAL1 GND is disconnected from power	85	ABS :	20	
	Low voltage (DIAGONAL1 POWER)	81	Does'nt active at FRT RH,	21	
	DIAGONAL1 POWER CUT	85	REAR LH,3RD LH	22	
	Abnormal valve relay DIAGONAL1 Power	83	Doesn't active at ATC	23	
	DIAGONAL1 GND is disconnected	85	ABS: Active,Warning lamp: ON	24	
	DIAGONAL2 GND is disconnected from power	85	ABS :	25	
	Low voltage (DIAGONAL2 POWER)	81	Does'nt active at FRT RH,	26	
	DIAGONAL2 POWER CUT	85	REAR LH,3RD LH	27	
	Abnormal valve relay DIAGONAL2 Power	83	Doesn't active at ATC	23	
	DIAGONAL2 GND is disconnected	85	ABS: Active,Warning lamp: ON	29	
	DIAGONAL 1,2 Over voltage	82	Doesn't active at ATC,ABS	49	
Diff Brake Valve	Short at power supply	72	ABS :	17	
	Circuit cut	72	Does'nt active at FRT RH, REAR LH,3RD LH	18	
	Short at ground	72	Doesn't active at DIFF.LOCK	19	
Diff Lock	Short at power supply	76	ABS :	17	
	Circuit cut	76	Does'nt active at FRT RH, REAR LH,3RD LH	18	
	Short at ground	76	Doesn't active at ATC	19	
PROP Valve	Short at power supply	76	Doesn't active at DIFF.LOCK	17	
	Circuit cut	76		18	
	Short at ground	76		19	
Warning lamp	Abnormal warning lamp	74	Always light on	40	
CAN	Abnormal	71	ATC : Active	41	
	Cut	71	Doesn't active at ATC	42	
	Short at ground	71		43	
	Too much time	71		44	
	Internal error	83		45	
CONFIGURA- TION	Abnormal ATC	75	Doesn't active at ATC,ABS	50	
	Abnormal ABS	84		51	
EEPROM	Abnormal wheel parameter	84	Doesn't active at ATC,ABS	52	
	Abnormal check sum	84		53	
ECU	Internal error	83	Doesn't active at ATC,ABS	54	
	Short at load	84		55	
	Over slip/ dienamо test	71		56	
	Modulater valve operating time	21		57	
	Internal error	83		58	

SID : Subsystem Identifier

FMI : Fault mode Identifier

WSS : Wheel Speed Sensor

Code	Fault cause / repair
1	Vehicle speed amplitude is too low. Check axle bearing, pulse ring teeth and push the sensor fully once again.
2	Tire size or the number of pulse ring teeth is different from other wheels.
3	Check wire ring. DC power is detected at sensor wire.
4	Check sensor wiring. Replace the sensor if needed. Ground short is detected. Normal value is approximately 1.6 k Ω .
5	Check sensor wiring. Replace the sensor if needed. Circuit short is detected.
6	Check sensor wiring. Replace the sensor if needed. Short between 2 sensor wires (IG/IGM) is detected.
7	Check any damage of pulse ring with the tester. Replace it if it gets faulty repeatedly. If air gap code is detected along with this code, adjust the air gap. Air gap is displayed periodically with its rotations.
8	Adjust the air gap. This code is displayed when the slip is detected more than 16 seconds. (In case of dynamo test)
9	Check the inconsistency with other sensors. IG or IGM of other sensors is detected. Repair the circuit.
10	Check the air gap. Check any poor connection between wire and connector. Measure the amplitude of sensor signals and compare it with the specified value. Fault code due to wrong signals of the temporary wheel speed sensor.
11	Check any poor connection between wire and connector. Check any damage on pulse ring. Measure the amplitude of sensor signals and compare it with the specified value. No countermeasure is available if it is due to brake squeeze or chattering.
12	Check any poor connection between wire and connector. Replace ECU, if the fault repeats.
13	Check the modulator wire. Common mode of inlet (EV) or outlet (AV) is disconnected temporarily or permanently. In case of normal, the value of AV to common and EV to common is approximately 5.5 Ω , and the value from AV to EV is about 1.1 Ω .
14	Check the modulator wire. Inlet (EV) or outlet (AV) circuit is short form the power.
15	Check the modulator wire. Inlet (EV) or outlet (AV) circuit is blown. It's identical with code. 13.
16	Check the modulator wire. Inlet (EV) or outlet (AV) circuit is disconnected from GND.
17	Check wire. Output is disconnected from power.
18	Check wire. Output is disconnected.
19	Check wire. Output is disconnected from GND.
20	Check front LH, rear RH, 3rd RH modulator wire. Common mode of modulator is disconnected from the power.
21	Check power wire and fuse. Voltage is too low.
22	Check terminal 12 (GND) of 18P connector. It's not connected to GND.
23	If this fault repeats, replace ECU. Inner relay of ECU is wrong.
24	Check front LH, rear RH, 3rd RH modulator wire. Common mode of modulator is disconnected from GND
25	Check front RH, rear LH, 3rd LH modulator wires. Common mode of modulator is disconnected from the power
26	Check power wire and fuse. Voltage is too low.
27	Check terminal 11 (GND) of 19P connector. It's not connected to GND.
29	Check front RH, rear LH, 3rd LH modulator wires. Common mode of modulator is disconnected from GND.
40	Check wire and IND bulb. Have you ever pressed ABS check switch more than 16 seconds? Output mode cannot detect the load. Adjust wheel speed sensor signal or check tire size.
41	Adjust wheel speed sensor signal or check tire size.

Code	Fault cause / repair
42	Check wire. More than one SAE J1939 data link wire is not connected.
43	Check wire. More than one SAE J1939 data link wire is disconnected.
44	Check other ECU, which uses SAE J1939. That ECU transmits wrong signals.
45	If this fault repeats, replace ECU.
49	Check alternator and battery. It shows too high voltage more than 5 seconds.
50	Check the parameter setting. Diff valve is detected under the condition of no Engine Control Unit (CAN, PWM, PROP)
51	Wrong ECU
52	Check the parameter setting. If this fault repeats, replace ECU.
53	Check the parameter setting. Didn't you remove the connector while diagnosing with diagnostic equipment? Reset the parameter.
54	Replace ECU if this fault repeats.
55	Modulator is not connected. This fault is not memorized. It is normal if this code shows up in the EOL test where CAB is only assembled.
56	Check air gap. One axle rotated faster than the other axle. It is normal if it shows up in the speed test of R/T.
57	Modulator keeps operating more than 3 minutes. It comes back to normal after some delay.
58	Replace ECU if this fault repeats.
59	Check wire. No load on the DBR output mode. Load was detected before. Reset the parameter setting if there is no actual load.

PARKING BRAKE

GENERAL	BRc - 2
SPECIFICATIONS	BRc - 3
SERVICE STANDARDS	BRc - 3
SERVICE PROCEDURE	BRc - 4
TROUBLESHOOTING	BRc - 9



GENERAL

When the parking brake lever inside the cab is pulled up, the shoes of the parking brake located behind the transmission press against the drum to bring the vehicle to a stop.

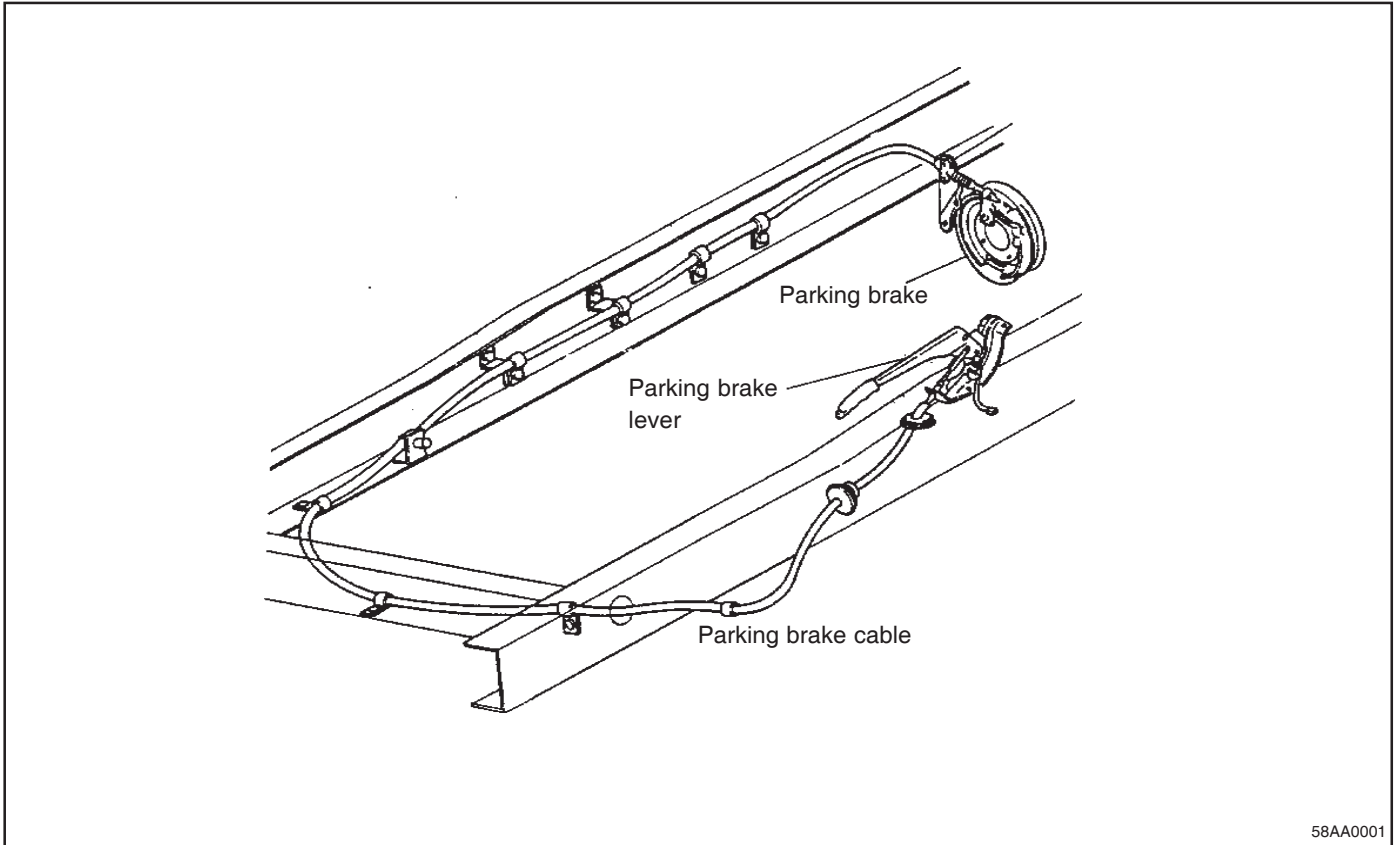

58AA0001

Parking Brake Lever

The parking brake lever incorporates a lock mechanism which holds the lever in the raised position. Pressing the knob at the end of the lever disengages the pawl of the lock plate from the tooth of the bracket, the lever becomes unlocked, and can return to its original position.

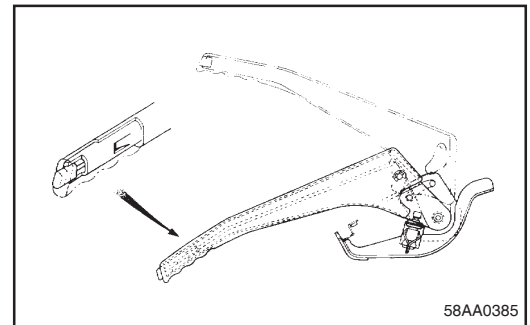

58AA0385

Parking Brake

When the parking brake lever is pulled up, the control wire pulls on the camshaft lever and the camshaft rotates. This expands the shoe and lining assembly. The expanded shoes press against the drum, and the friction applied to the drum surface controls the rotation of the propeller shaft that is connected to the brake drum. If the parking brake lever is released, the return spring pulls the camshaft lever back to its original position. The shoe and lining assembly separates from the brake drum surface by the force of the shoe return springs, and the brake drum and propeller shaft are freed.

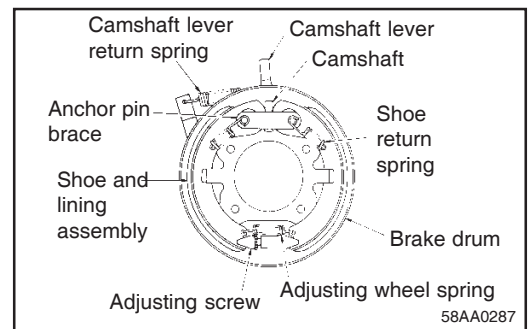

58AA0287

SPECIFICATIONS

Description	Transmission model	KH10, M6S6
Parking brake type	Internal expansion type acting on propeller shaft	
Brake drum I. D.	203.2 mm	
Brake lining width x thickness	50 x 40 mm	
Control	Mechanical control with wire	
	Air control type	

SERVICE STANDARDS

Service Standards Table

Maintenance item			Nominal value (Basic diameter in [])	Limit	Remedy and remarks
Parking brake lever stroke (number of detents)			7 to 10	-	Adjust
Brake drum			$\varnothing 203.2 \begin{matrix} +0.3 \\ 0 \end{matrix}$	205	Repair if the service limit has not yet been reached; replace if the limit has been exceeded
	Static rotational imbalance		0.88 Ncm (90 gfcM) or less	-	Replace
Brake lining thickness			4.0	1.4	Replace
Shoe clearance			0.1 to 0.25	-	Adjust
Shoe return spring	Load/installed length	M5S	145 N (15 kgf)/57.5	115 N (12 kgf) /57.5	Replace
Adjusting wheel return spring	Load/installed length		78 N (8 kgf)/59	63 N (6.4 kgf) /59	Replace

Tightening Torque Table

Location tightened	Screw size O.D. x pitch (mm)	Tightening torque Nm (kgfm)
Camshaft lever fastening nut	M8 x 1.25	6.9 to 13 (0.7 to 1.3)
Transmission main shaft and transfer driver shaft rear lock nuts	M27 x 1.5	245 to 345 (25 to 35)

SERVICE PROCEDURE

Parking Brake

Removal and installation

- (1) Before removing the parking brake, apply chocks to the front wheels.
- (2) For removal of the propeller shaft, refer to Propeller shaft section.
- (3) When removing the companion flange, use care not to cause damage to the oil seal.
- (4) Remove the parking brake control.
- (5) Removal and installation of the transmission main shaft rear lock nut.

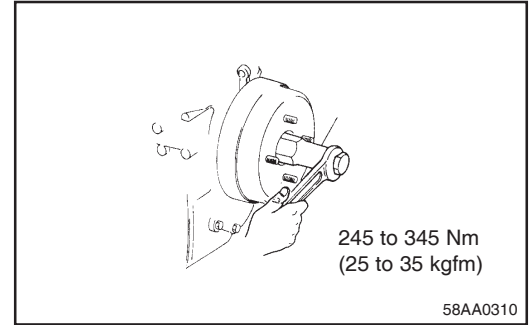

Disassembly and inspection

Deterioration Load/Installed length

NV 145 N (15 kgf)/57.5

L 115 N (12 kgf)/57.5

Contamination, burn, hardening by aging cracks, damage

Lining thickness

NV 4.0

L 1.4

Drum diameter

NV $\varnothing 203.2^{+0.3}_0$

L 205

Uneven wear, cracks, score
(Use a lathe for correction)

Deterioration Load/Installed length

NV 78 N (8 kgf)/59

L 63 N (6.4 kgf)/59

NV Nominal Value

L Limit

Disassembly sequence

<ol style="list-style-type: none"> 1. Parking brake drum 2. Shoe return spring 3. Adjusting wheel return spring 4. Adjusting screw and nut assembly 5. Shoe and lining assembly 6. Anchor pin brace 	<ol style="list-style-type: none"> 7. Cam shaft lever return spring 8. Cam shaft 9. Cam shaft lever 10. Spring spacer 11. Support plate 12. Dust cover
---	--

Reassembly

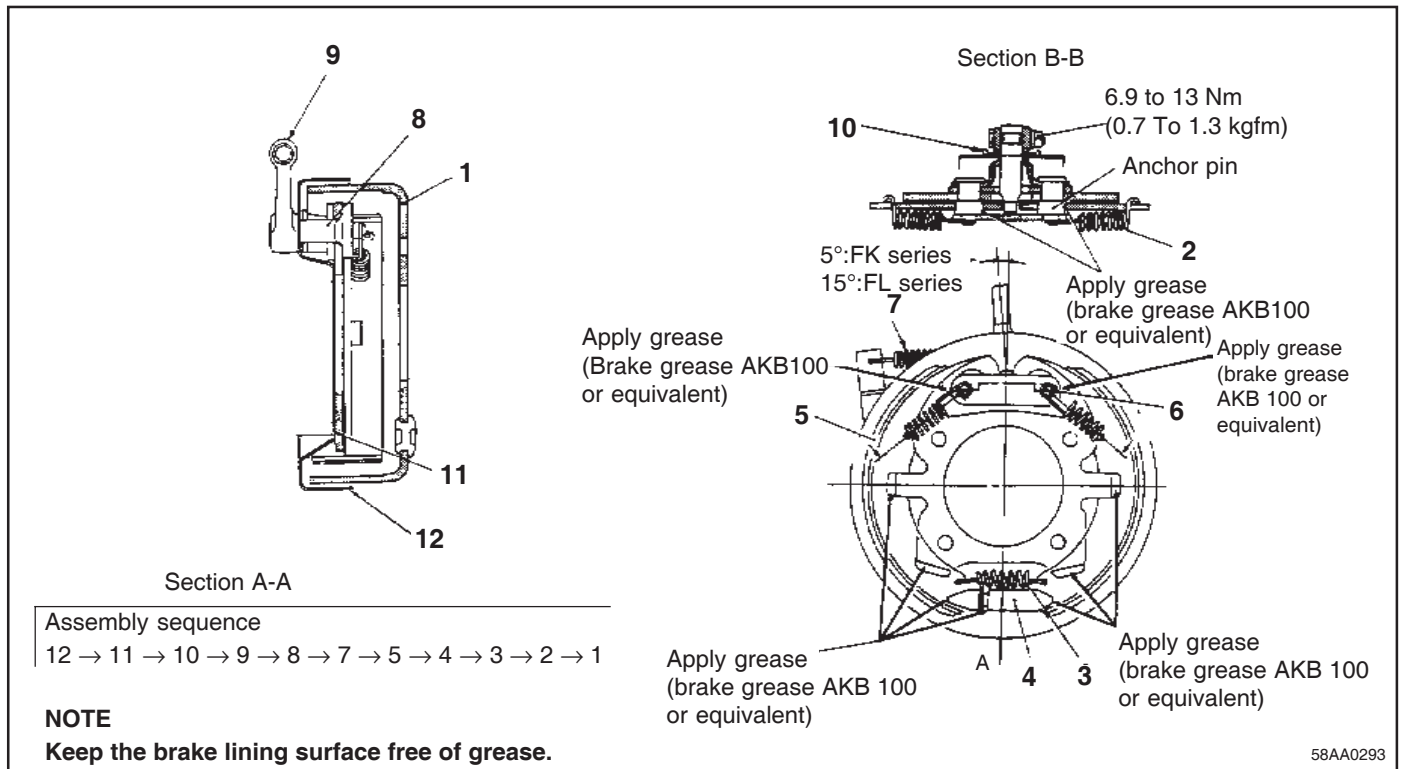

Parking Brake Control

Removal and installation

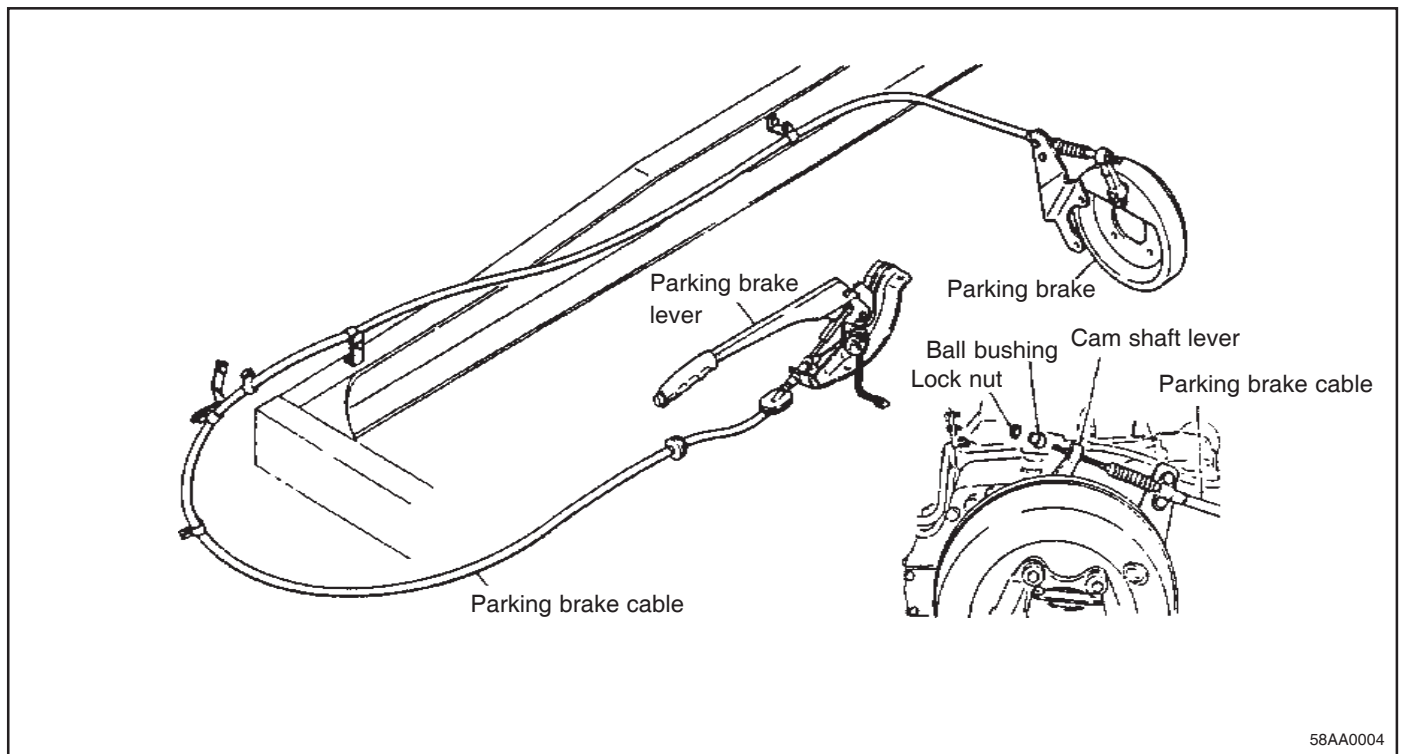

**Parking brake lever
Disassembly**

Deterioration
Reassembly

Removal procedure

1. Pilot switch
2. Pin
3. Snap ring
4. Pin
5. Lock latch
6. Knob
7. Return spring
8. Grip
9. Release rod
10. Parking brake lever
11. Parking brake bracket

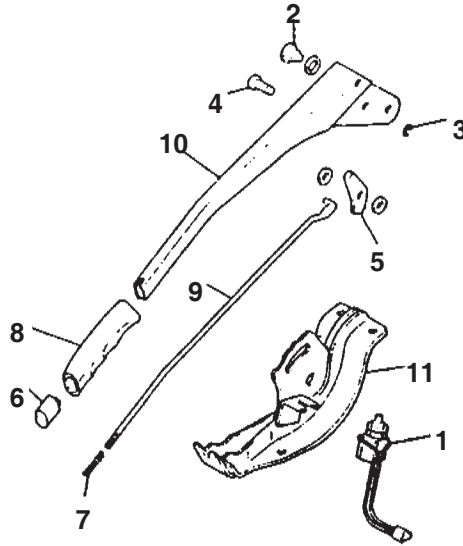

58AA0127

Apply adhesive when screwing in
Stroke

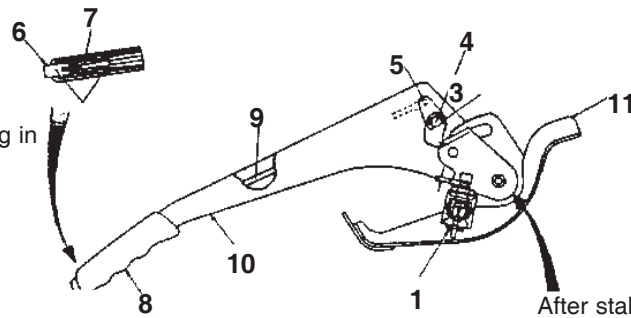

Before staking

	Without spacer	With spacer
Nominal value	Less than 0.6	0.6~0.96

After staking

	Without spacer	With spacer
Nominal value	0.06 to 0.6	0 to 0.36

After staking

Spacer



Before staking

58AA0007

Air Parking Brake

\The air parking brake uses compressed air generated by air compressor to operate parking brake.

When the parking brake is released, the compressed air is sent to remote air chamber through dash control valve and quick release valve to overcome the spring tension inside the remote air chamber causing the parking cable to be loosened.

When the parking brake is applied, the dash control valve makes the compressed air to be extracted through quick release valve, thereby the parking brake cable is pressed by spring tension of remote chamber to tighten the propeller shaft.

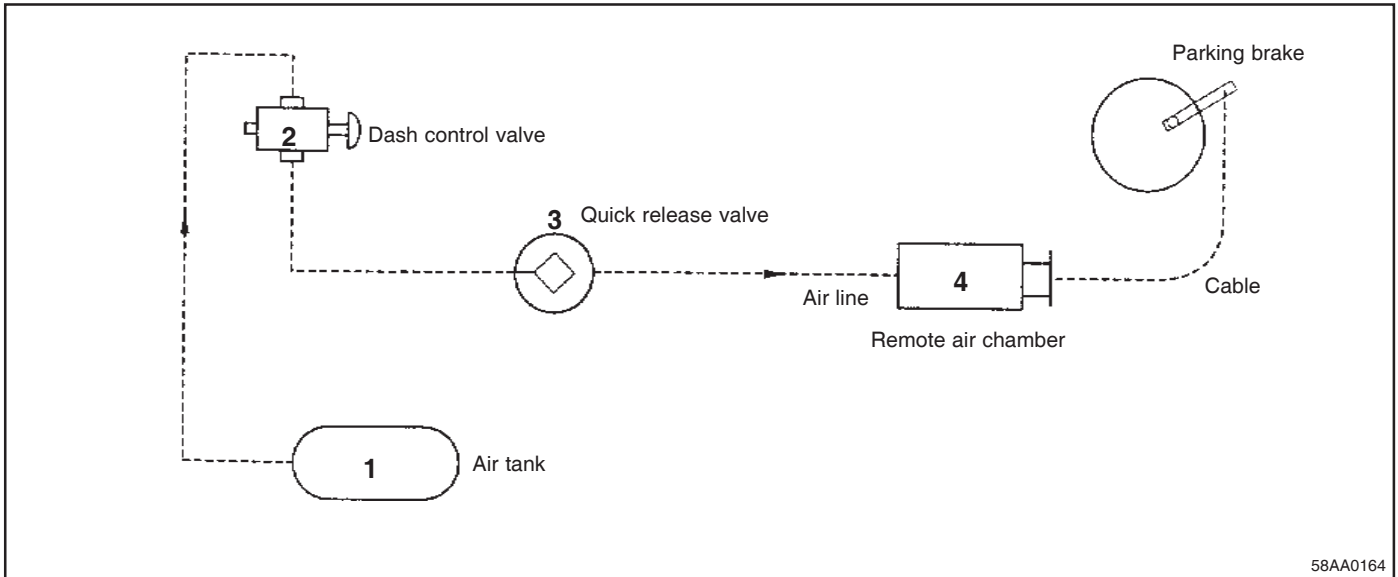

Air parking brake adjustment

- 1) Fill the air tank with compressed air (6 kgf/cm² or more) and push the CAB control valve to actuate the remote air chamber.
- 2) Connect the clevis of parking brake to remote chamber.
- 3) Hard-tight the parking brake assembly ball so that the play of lever is to 1~2 mm.
- 4) Adjust the remote air chamber stroke to be 30~33 mm with ball while pulling the CAB control valve and tighten the nut.
- 5) Adjust the brake lining clearance to be nominal value (0.1~0.25 mm) if occurs slipping in parking brake.

Inspection of parking brake.

If the stroke of remote chamber push rod is 25 mm or more, adjust the lining clearance so that the stroke of chamber is 30~33 mm.

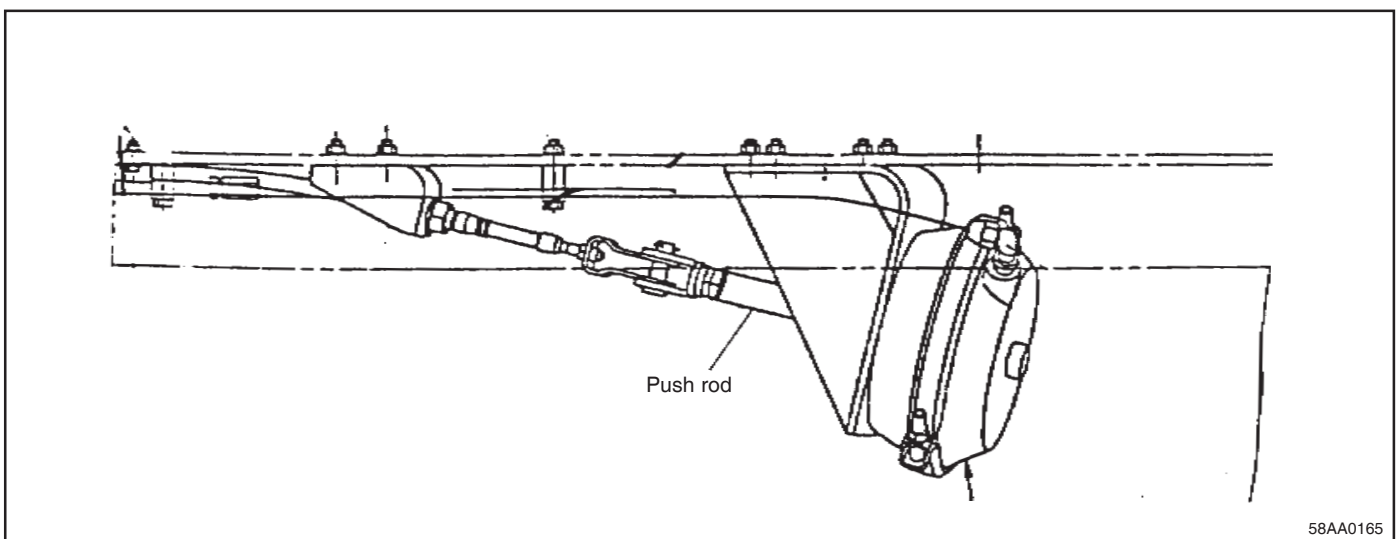

Adjustment

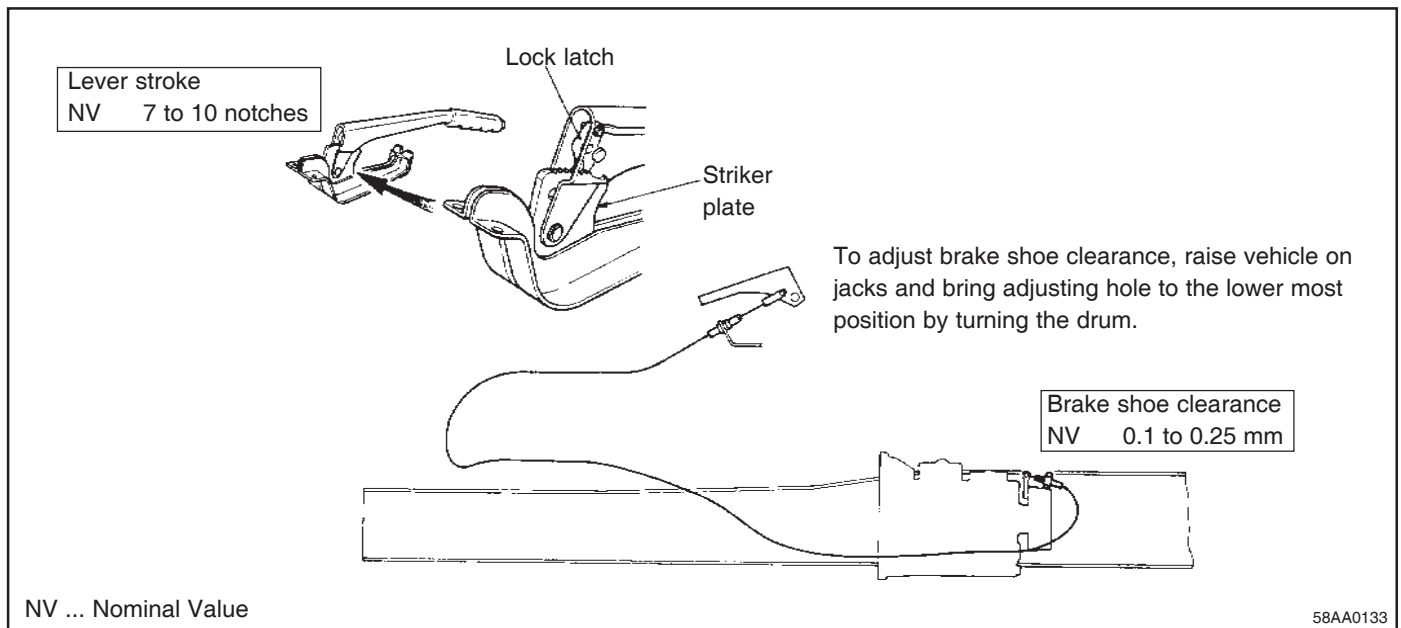

Place the camshaft lever in its released position.
 Turn the adjusting screw by using a screwdriver through the shoe clearance adjusting hole in the drum until the shoes firmly contact the drum, and then back off the screw 8 notches. The shoe clearance then should be the nominal value of 0.1 to 0.25 mm.

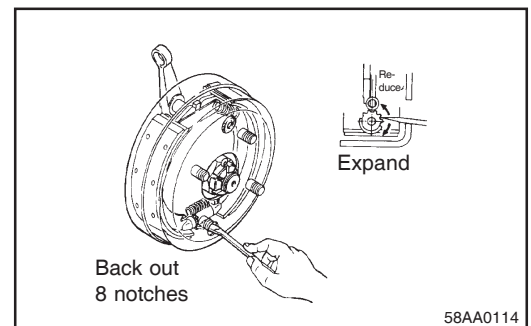

Adjust the parking brake lever stroke by turning the cam shaft lever lock nut so that the number of the clicks produced when the lever is pulled up all the way from its released position with a force of 295 N (30 kgf) corresponds to the nominal value (7 to 10 notches).

After making the adjustment, operate the parking brake lever two or three times to make sure that the stroke is correctly adjusted, the parking brake operates normally and the brake drum does not drag.

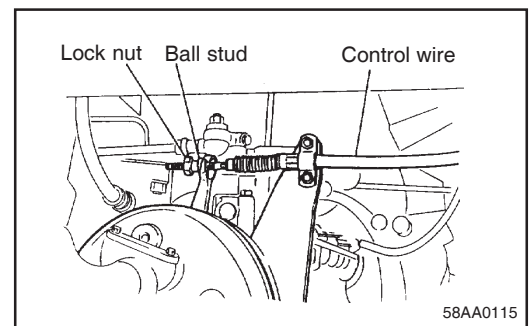

TROUBLESHOOTING

Symptom	Probable cause	Remedy	
Parking brake does not work	Problems with the parking brake control mechanism	Adjust shoe clearance and control wire	
	<ul style="list-style-type: none"> o No shoe clearance and no play in lever stroke when the parking brake lever is pulled up with a force of 295 N (30 kgf). 		
	<ul style="list-style-type: none"> o Poor engagement between parking brake lever assembly lock plate pawl and bracket tooth 		Correct bracket installation for proper engagement or replace part which is defective
	<ul style="list-style-type: none"> o Elongated or broken parking brake control wire 	Replace control wire	
	Problems with shoe and drum assembly	Adjust brake shoe clearance	
	<ul style="list-style-type: none"> o Excessive shoe clearance and resultant increase of parking brake lever stroke 		
	<ul style="list-style-type: none"> o Deformed or distorted drum 		Correct by grinding drum inner surface or replace drum
	<ul style="list-style-type: none"> o Unevenly worn shoe lining due to uneven contact with drum 		Replace shoe and lining assembly
<ul style="list-style-type: none"> o Oil or grease on drum inner surface or shoe lining 	Clean drum inner surface and replace shoe and lining assembly		
Inadequate release of parking brake	Problems with parking brake control mechanism	Replace return spring	
	<ul style="list-style-type: none"> o Weakened or broken return spring of parking brake lever assembly 		
	<ul style="list-style-type: none"> o Incorrect parking brake lever stroke 	Adjust stroke	
	<ul style="list-style-type: none"> o Parking brake control wire does not move smoothly 	Adjust or replace control wire	
	<ul style="list-style-type: none"> o Elongated control wire inner cable 		
	<ul style="list-style-type: none"> o Excessive sliding resistance due to broken control wire inner cable 		
	Problems with shoe and drum assembly	Replace shoe return spring and/or camshaft lever return spring	
<ul style="list-style-type: none"> o Weakened or brake shoe return spring or camshaft lever return spring 			
<ul style="list-style-type: none"> o Too small brake shoe clearance 	Adjust brake shoe clearance		